

## Chapter 13. Current Electricity

1. The resistance of a wire is ' $R$ ' ohm. If it is melted and stretched to ' $n$ ' times its original length, its new resistance will be

(a)  $\frac{R}{n}$     (b)  $n^2R$     (c)  $\frac{R}{n^2}$     (d)  $nR$

(NEET 2017)

2. A potentiometer is an accurate and versatile device to make electrical measurements of EMF because the method involves

- (a) potential gradients  
 (b) a condition of no current flow through the galvanometer  
 (c) a combination of cells, galvanometer and resistances  
 (d) cells

(NEET 2017)

3. The potential difference ( $V_A - V_B$ ) between the points  $A$  and  $B$  in the given figure is

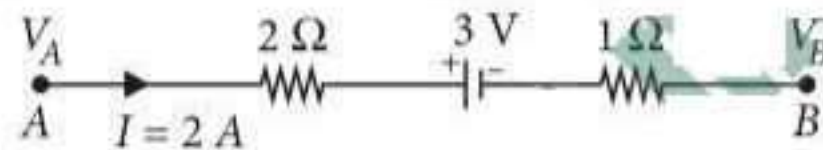

- (a)  $-3\text{ V}$     (b)  $+3\text{ V}$     (c)  $+6\text{ V}$     (d)  $+9\text{ V}$

(NEET-II 2016)

4. A filament bulb ( $500\text{ W}, 100\text{ V}$ ) is to be used in a  $230\text{ V}$  main supply. When a resistance  $R$  is connected in series, it works perfectly and the bulb consumes  $500\text{ W}$ . The value of  $R$  is

- (a)  $230\ \Omega$     (b)  $46\ \Omega$     (c)  $26\ \Omega$     (d)  $13\ \Omega$

(NEET-II 2016)

5. A potentiometer wire is  $100\text{ cm}$  long and a constant potential difference is maintained across it. Two cells are connected in series first to support one another and then in opposite direction. The balance points are obtained at  $50\text{ cm}$  and  $10\text{ cm}$  from the positive end of the wire in the two cases. The ratio of emf's is

- (a)  $3 : 4$     (b)  $3 : 2$     (c)  $5 : 1$     (d)  $5 : 4$

(NEET-I 2016)

6. The charge flowing through a resistance  $R$  varies with time  $t$  as  $Q = at - bt^2$ , where  $a$  and  $b$  are

positive constants. The total heat produced in  $R$  is

(a)  $\frac{a^3R}{2b}$     (b)  $\frac{a^3R}{b}$     (c)  $\frac{a^3R}{6b}$     (d)  $\frac{a^3R}{3b}$

(NEET-I 2016)

7. Two metal wires of identical dimensions are connected in series. If  $\sigma_1$  and  $\sigma_2$  are the conductivities of the metal wires respectively, the effective conductivity of the combination is

(a)  $\frac{\sigma_1 + \sigma_2}{\sigma_1\sigma_2}$     (b)  $\frac{\sigma_1\sigma_2}{\sigma_1 + \sigma_2}$   
 (c)  $\frac{2\sigma_1\sigma_2}{\sigma_1 + \sigma_2}$     (d)  $\frac{\sigma_1 + \sigma_2}{2\sigma_1\sigma_2}$     (2015)

8. A circuit contains an ammeter, a battery of  $30\text{ V}$  and a resistance  $40.8\text{ ohm}$  all connected in series. If the ammeter has a coil of resistance  $480\text{ ohm}$  and a shunt of  $20\text{ ohm}$ , the reading in the ammeter will be

- (a)  $2\text{ A}$     (b)  $1\text{ A}$     (c)  $0.5\text{ A}$     (d)  $0.25\text{ A}$

(2015)

9. A potentiometer wire of length  $L$  and a resistance  $r$  are connected in series with a battery of e.m.f.  $E_0$  and a resistance  $r_1$ . An unknown e.m.f.  $E$  is balanced at a length  $l$  of the potentiometer wire. The e.m.f.  $E$  will be given by

(a)  $\frac{E_0 l}{L}$     (b)  $\frac{LE_0 r}{(r + r_1)l}$   
 (c)  $\frac{LE_0 r}{lr_1}$     (d)  $\frac{E_0 r}{(r + r_1)} \cdot \frac{l}{L}$     (2015)

10.  $A, B$  and  $C$  are voltmeters of resistance  $R, 1.5R$  and  $3R$  respectively as shown in the figure. When some potential difference is applied between  $X$  and  $Y$ , the voltmeter readings are  $V_A, V_B$  and  $V_C$  respectively. Then

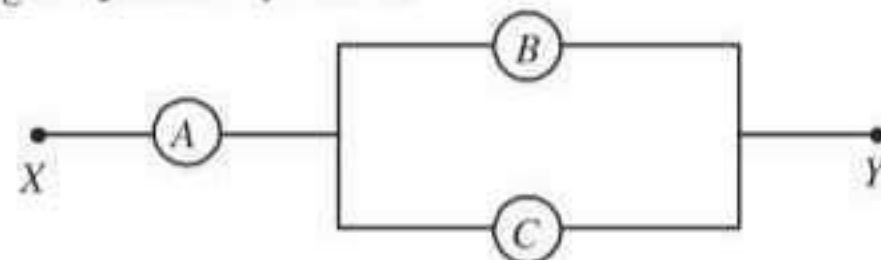

- (a)  $V_A = V_B \neq V_C$       (b)  $V_A \neq V_B \neq V_C$   
 (c)  $V_A = V_B = V_C$       (d)  $V_A \neq V_B = V_C$   
 (2015 Cancelled)

11. Across a metallic conductor of non-uniform cross section a constant potential difference is applied. The quantity which remains constant along the conductor is

- (a) drift velocity      (b) electric field  
 (c) current density      (d) current

(2015 Cancelled)

12. A potentiometer wire has length 4 m and resistance  $8 \Omega$ . The resistance that must be connected in series with the wire and an accumulator of e.m.f. 2 V, so as to get a potential gradient 1 mV per cm on the wire is

- (a)  $44 \Omega$     (b)  $48 \Omega$     (c)  $32 \Omega$     (d)  $40 \Omega$

(2015 Cancelled)

13. The resistances in the two arms of the meter bridge are  $5 \Omega$  and  $R \Omega$  respectively. When the resistance  $R$  is shunted with an equal resistance, the new balance point is at  $1.6l_1$ . The resistance  $R$  is

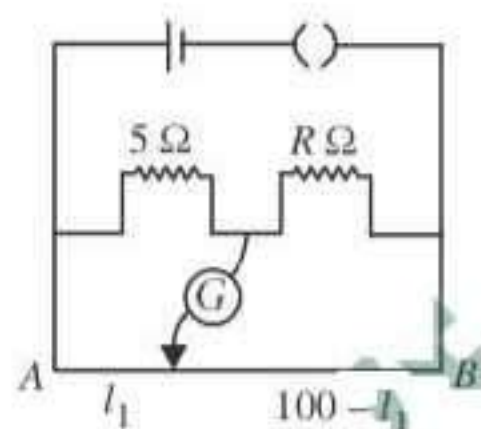

- (a)  $10 \Omega$     (b)  $15 \Omega$     (c)  $20 \Omega$     (d)  $25 \Omega$

(2014)

14. Two cities are 150 km apart. Electric power is sent from one city to another city through copper wires. The fall of potential per km is 8 volt and the average resistance per km is  $0.5 \Omega$ . The power loss in the wire is

- (a)  $19.2 \text{ W}$       (b)  $19.2 \text{ kW}$   
 (c)  $19.2 \text{ J}$       (d)  $12.2 \text{ kW}$     (2014)

15. A potentiometer circuit has been set up for finding the internal resistance of a given cell. The main battery, used across the potentiometer wire, has an emf of 2.0 V and a negligible internal resistance. The potentiometer wire itself is 4 m long. When the resistance  $R$ , connected across the given cell, has values of

- (i) infinity      (ii)  $9.5 \Omega$

the balancing lengths on the potentiometer wire are found to be 3 m and 2.85 m, respectively. The value of internal resistance of the cell is

- (a)  $0.25 \Omega$       (b)  $0.95 \Omega$   
 (c)  $0.5 \Omega$       (d)  $0.75 \Omega$     (2014)

16. The resistances of the four arms  $P$ ,  $Q$ ,  $R$  and  $S$  in a Wheatstone's bridge are 10 ohm, 30 ohm, 30 ohm and 90 ohm, respectively. The e.m.f. and internal resistance of the cell are 7 volt and 5 ohm respectively. If the galvanometer resistance is 50 ohm, the current drawn from the cell will be

- (a) 0.1 A    (b) 2.0 A    (c) 1.0 A    (d) 0.2 A

(NEET 2013)

17. The internal resistance of a 2.1 V cell which gives a current of 0.2 A through a resistance of  $10 \Omega$  is

- (a)  $0.8 \Omega$     (b)  $1.0 \Omega$     (c)  $0.2 \Omega$     (d)  $0.5 \Omega$

(NEET 2013)

18. A wire of resistance  $4 \Omega$  is stretched to twice its original length. The resistance of stretched wire would be

- (a)  $8 \Omega$     (b)  $16 \Omega$     (c)  $2 \Omega$     (d)  $4 \Omega$

(NEET 2013)

19. Two rods are joined end to end, as shown. Both have a cross-sectional area of  $0.01 \text{ cm}^2$ .

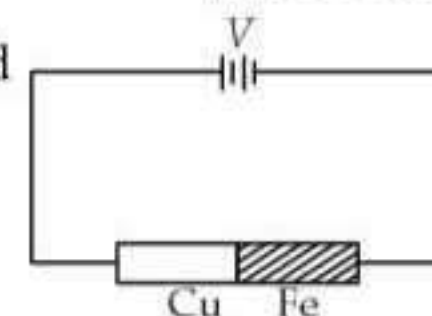

Each is 1 meter long. One rod is of copper with a resistivity of  $1.7 \times 10^{-6}$  ohm-centimeter, the other is of iron with a resistivity of  $10^{-5}$  ohm-centimeter.

How much voltage is required to produce a current of 1 ampere in the rods?

- (a)  $0.00145 \text{ V}$     (b)  $0.0145 \text{ V}$   
 (c)  $1.7 \times 10^{-6} \text{ V}$     (d)  $0.117 \text{ V}$

(Karnataka NEET 2013)

20. A 12 cm wire is given a shape of a right angled triangle  $ABC$  having sides 3 cm, 4 cm and 5 cm as shown in the figure. The

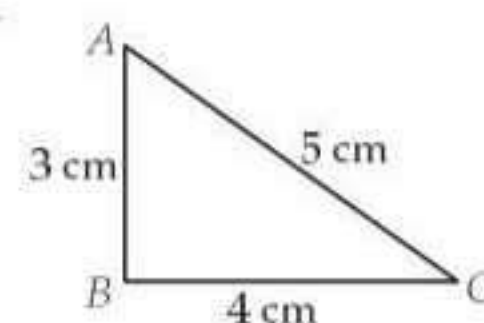

resistance between two ends ( $AB$ ,  $BC$ ,  $CA$ ) of the respective sides are measured one by one by a multi-meter. The resistances will be in the ratio

- (a) 9 : 16 : 25      (b) 27 : 32 : 35  
 (c) 21 : 24 : 25      (d) 3 : 4 : 5

(Karnataka NEET 2013)

21. Ten identical cells connected in series are needed to heat a wire of length one meter and radius ' $r$ ' by  $10^\circ\text{C}$  in time ' $t$ '. How many cells will be

required to heat the wire of length two meter of the same radius by the same temperature in time 't'?

- (a) 20 (b) 30 (c) 40 (d) 10

(Karnataka NEET 2013)

22. In the circuit shown the cells A and B have negligible resistances. For  $V_A = 12\text{ V}$ ,  $R_1 = 500\ \Omega$  and  $R = 100\ \Omega$  the galvanometer (G) shows no deflection. The value of  $V_B$  is

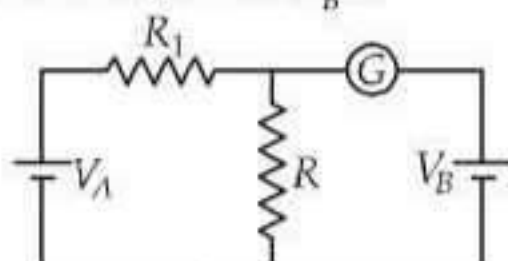

- (a) 4 V (b) 2 V (c) 12 V (d) 6 V

(2012)

23. A ring is made of a wire having a resistance  $R_0 = 12\ \Omega$ . Find the points A and B, as shown in the figure, at which a current carrying conductor should be connected so that the resistance  $R$  of the sub circuit between these points is equal to  $\frac{8}{3}\ \Omega$ .

(a)  $\frac{l_1}{l_2} = \frac{5}{8}$

(b)  $\frac{l_1}{l_2} = \frac{1}{3}$

(c)  $\frac{l_1}{l_2} = \frac{3}{8}$

(d)  $\frac{l_1}{l_2} = \frac{1}{2}$



(2012)

24. If voltage across a bulb rated 220 volt-100 watt drops by 2.5% of its rated value, the percentage of the rated value by which the power would decrease is

- (a) 20% (b) 2.5% (c) 5% (d) 10%

(2012)

25. A cell having an emf  $\epsilon$  and internal resistance  $r$  is connected across a variable external resistance  $R$ . As the resistance  $R$  is increased, the plot of potential difference  $V$  across  $R$  is given by

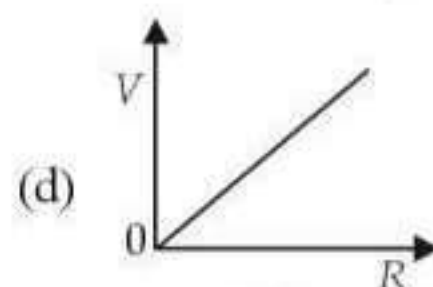
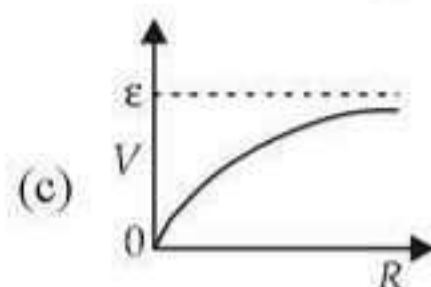
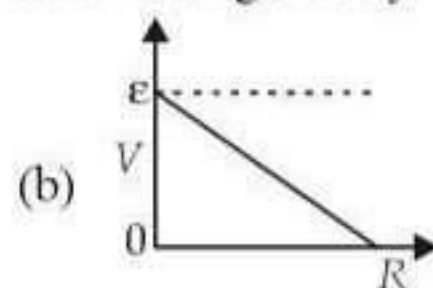
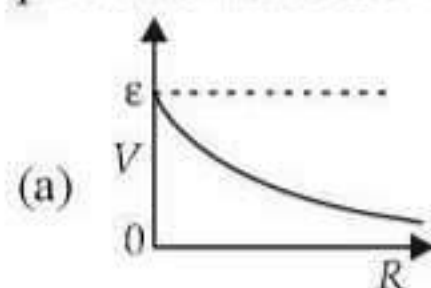

(Mains 2012)

26. The power dissipated in the circuit shown in the figure is 30 watts. The value of  $R$  is

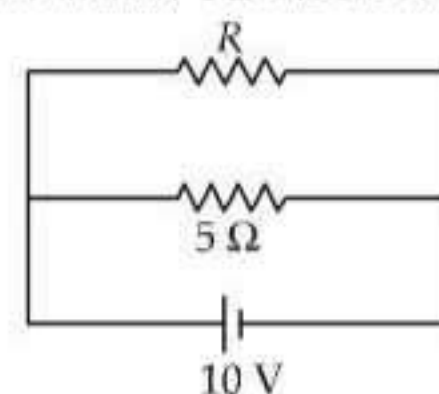

- (a) 20  $\Omega$  (b) 15  $\Omega$  (c) 10  $\Omega$  (d) 30  $\Omega$

(Mains 2012)

27. A current of 2 A flows through a 2  $\Omega$  resistor when connected across a battery. The same battery supplies a current of 0.5 A when connected across a 9  $\Omega$  resistor. The internal resistance of the battery is

- (a) 0.5  $\Omega$  (b) 1/3  $\Omega$  (c) 1/4  $\Omega$  (d) 1  $\Omega$

(2011)

28. If power dissipated in the 9  $\Omega$  resistor in the circuit shown is 36 watt, the potential difference across the 2  $\Omega$  resistor is

- (a) 4 volt

- (b) 8 volt

- (c) 10 volt

- (d) 2 volt

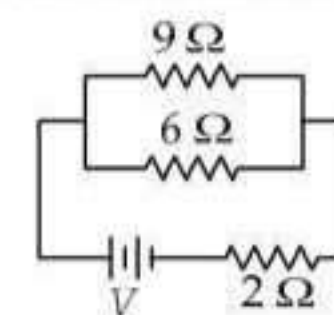

(2011)

29. In the circuit shown in the figure, if the potential at point A is taken to be zero, the potential at point B is

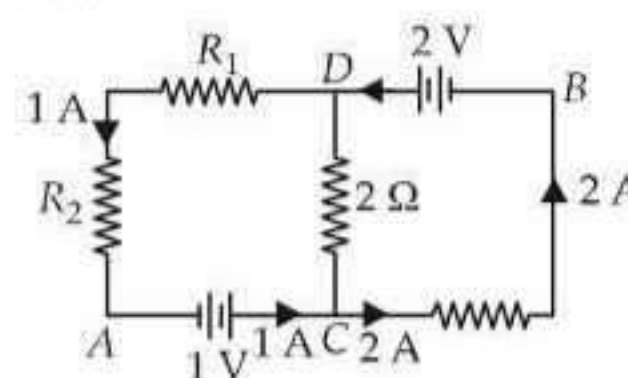

- (a) +1 V (b) -1 V (c) +2 V (d) -2 V

(Mains 2011)

30. Consider the following two statements.

(A) Kirchhoff's junction law follows from the conservation of charge.

(B) Kirchhoff's loop law follows from the conservation of energy.

Which of the following is correct?

- (a) Both (A) and (B) are wrong

- (b) (A) is correct and (B) is wrong

- (c) (A) is wrong and (B) is correct

- (d) Both (A) and (B) are correct (2010)

31. A potentiometer circuit is set up as shown. The potential gradient, across the potentiometer wire, is  $k$  volt/cm and the ammeter, present in the circuit, reads 1.0 A when two way key is switched off. The balance points, when the key between the terminals (i) 1 and 2 (ii) 1 and 3, is plugged in, are found to be at lengths  $l_1$  cm and  $l_2$  cm respectively. The magnitudes, of the resistors  $R$  and  $X$ , in ohms, are then, equal, respectively, to

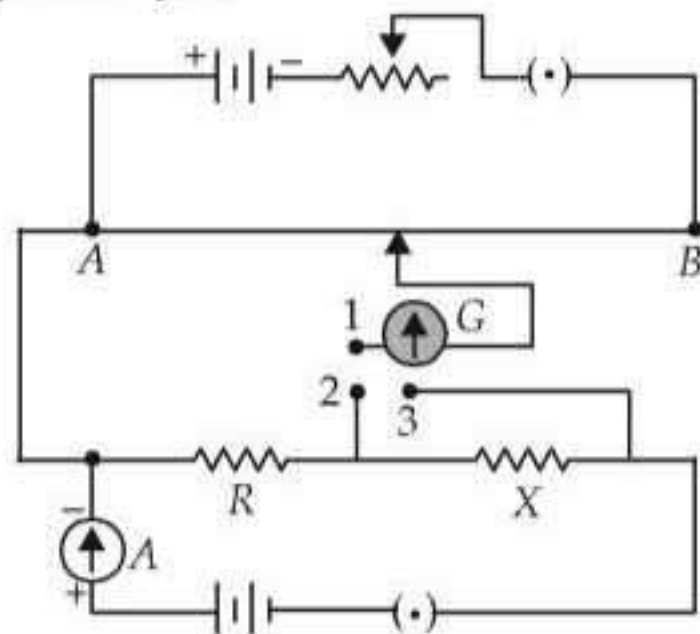

- (a)  $k(l_2 - l_1)$  and  $kl_2$  (b)  $kl_1$  and  $k(l_2 - l_1)$   
 (c)  $k(l_2 - l_1)$  and  $kl_1$  (d)  $kl_1$  and  $kl_2$  (2010)

32. See the electrical circuit shown in this figure. Which of the following equations is a correct equation for it?

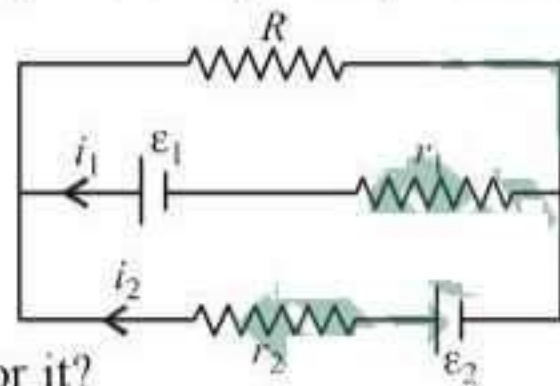

- (a)  $\epsilon_2 - i_2 r_2 - \epsilon_1 - i_1 r_1 = 0$   
 (b)  $-\epsilon_2 - (i_1 + i_2)R + i_2 r_2 = 0$   
 (c)  $\epsilon_1 - (i_1 + i_2)R + i_1 r_1 = 0$   
 (d)  $\epsilon_1 - (i_1 + i_2)R - i_1 r_1 = 0$  (2009)

33. A wire of resistance 12 ohms per meter is bent to form a complete circle of radius 10 cm. The resistance between its two diametrically opposite points, A and B as shown in the figure is

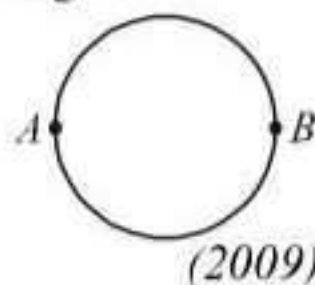

- (a)  $3 \Omega$   
 (b)  $6\pi \Omega$   
 (c)  $6 \Omega$   
 (d)  $0.6\pi \Omega$  (2009)

34. A student measures the terminal potential difference ( $V$ ) of a cell (of emf  $\epsilon$  and internal resistance  $r$ ) as a function of the current ( $I$ ) flowing through it. The slope, and intercept, of the graph between  $V$  and  $I$ , then, respectively, equal

- (a)  $-r$  and  $\epsilon$  (b)  $r$  and  $-\epsilon$   
 (c)  $-\epsilon$  and  $r$  (d)  $\epsilon$  and  $-r$  (2009)

35. The mean free path of electrons in a metal is  $4 \times 10^{-8}$  m. The electric field which can give on an average 2 eV energy to an electron in the metal will be in units V/m

- (a)  $5 \times 10^{-11}$  (b)  $8 \times 10^{-11}$   
 (c)  $5 \times 10^7$  (d)  $8 \times 10^7$  (2009)

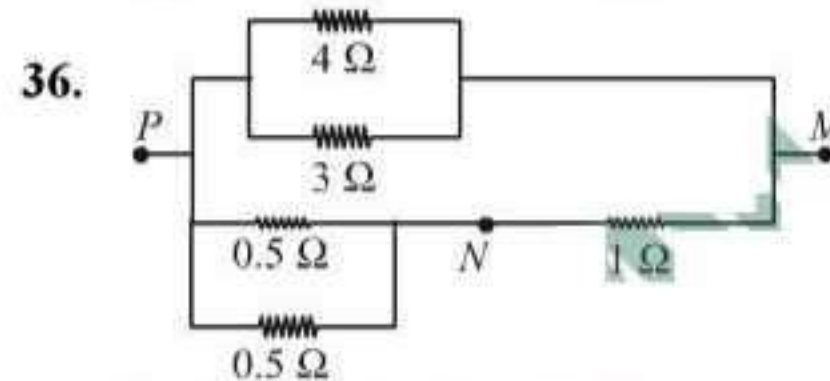

- In the circuit shown, the current through the  $4 \Omega$  resistor is 1 amp when the points P and M are connected to a d.c. voltage source. The potential difference between the points M and N is

- (a) 0.5 volt (b) 3.2 volt  
 (c) 1.5 volt (d) 1.0 volt (2008)

37. A wire of a certain material is stretched slowly by ten percent. Its new resistance and specific resistance become respectively

- (a) both remain the same  
 (b) 1.1 times, 1.1 times  
 (c) 1.2 times, 1.1 times  
 (d) 1.21 times, same (2008)

38. A cell can be balanced against 110 cm and 100 cm of potentiometer wire, respectively with and without being short circuited through a resistance of  $10 \Omega$ . Its internal resistance is

- (a) 2.0 ohm (b) zero  
 (c) 1.0 ohm (d) 0.5 ohm (2008)

39. An electric kettle takes 4 A current at 220 V. How much time will it take to boil 1 kg of water from temperature  $20^\circ\text{C}$ ? The temperature of boiling water is  $100^\circ\text{C}$

- (a) 12.6 min (b) 4.2 min  
 (c) 6.3 min (d) 8.4 min (2008)

40. A current of 3 amp. flows through the  $2 \Omega$  resistor shown in the circuit. The power dissipated in the  $5 \Omega$  resistor is

- (a) 1 watt  
 (b) 5 watt  
 (c) 4 watt  
 (d) 2 watt

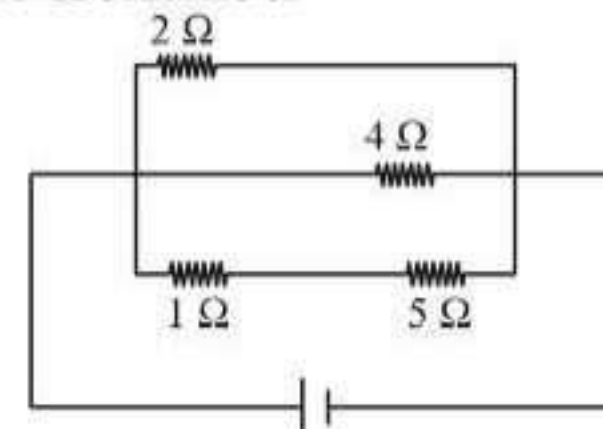

(2008)

41. Three resistances  $P, Q, R$  each of  $2\ \Omega$  and an unknown resistance  $S$  form the four arms of a Wheatstone bridge circuit. When a resistance of  $6\ \Omega$  is connected in parallel to  $S$  the bridge gets balanced. What is the value of  $S$ ?  
 (a)  $3\ \Omega$  (b)  $6\ \Omega$  (c)  $1\ \Omega$  (d)  $2\ \Omega$ .

(2007)

42. The total power dissipated in watt in the circuit shown here is

- (a) 40  
 (b) 54  
 (c) 4  
 (d) 16.

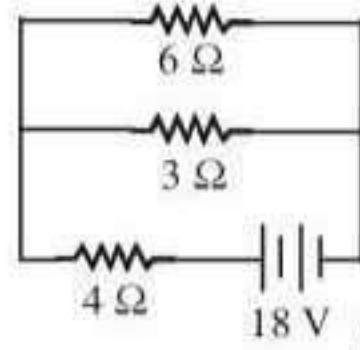

(2007)

43. In the circuit shown, if a conducting wire is connected between points  $A$  and  $B$ , the current in this wire will

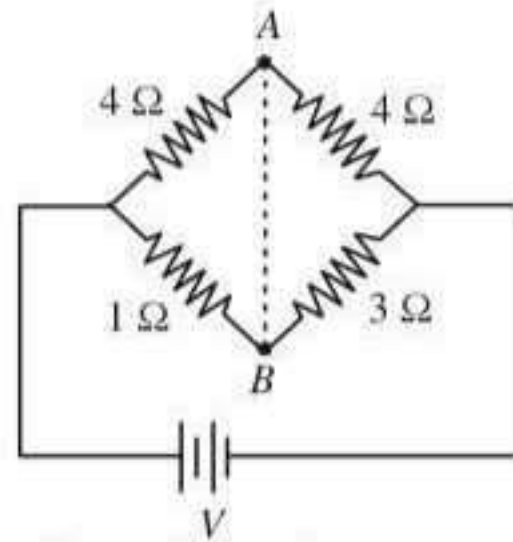

- (a) flow from  $B$  to  $A$   
 (b) flow from  $A$  to  $B$   
 (c) flow in the direction which will be decided by the value of  $V$   
 (d) be zero.

(2006)

44. Kirchhoff's first and second laws of electrical circuits are consequences of

- (a) conservation of energy and electric charge respectively  
 (b) conservation of energy  
 (c) conservation of electric charge and energy respectively  
 (d) conservation of electric charge.

(2006)

45. Two cells, having the same e.m.f. are connected in series through an external resistance  $R$ . Cells have internal resistances  $r_1$  and  $r_2$  ( $r_1 > r_2$ ) respectively. When the circuit is closed, the potential difference across the first cell is zero. The value of  $R$  is

- (a)  $r_1 + r_2$  (b)  $r_1 - r_2$  (c)  $\frac{r_1 + r_2}{2}$  (d)  $\frac{r_1 - r_2}{2}$

(2006)

46. Power dissipated across the  $8\ \Omega$  resistor in the circuit shown here is 2 watt. The power dissipated in watt units across the  $3\ \Omega$  resistor is

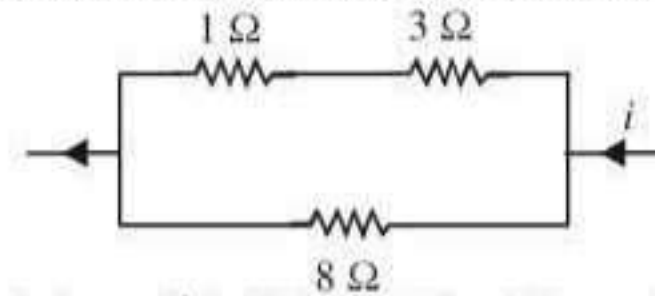

- (a) 3.0 (b) 2.0 (c) 1.0 (d) 0.5

(2006)

47. Two batteries, one of emf 18 volts and internal resistance  $2\ \Omega$  and the other of emf 12 volts and internal resistance  $1\ \Omega$ , are connected as shown. The voltmeter  $V$  will record a reading of

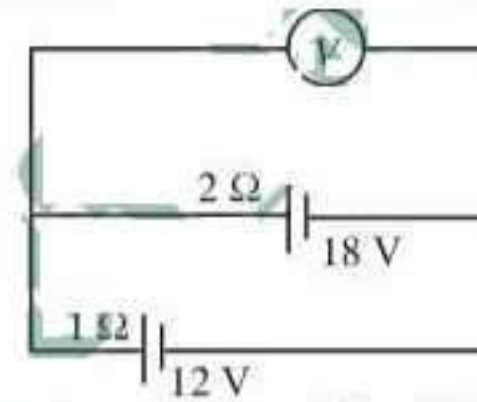

- (a) 30 volt (b) 18 volt  
 (c) 15 volt (d) 14 volt.

(2005)

48. When a wire of uniform cross-section  $a$ , length  $l$  and resistance  $R$  is bent into a complete circle, resistance between any two of diametrically opposite points will be

- (a)  $R/4$  (b)  $4R$  (c)  $R/8$  (d)  $R/2$ .

(2005)

49. For the network shown in the figure the value of the current  $i$  is

- (a)  $\frac{9V}{35}$   
 (b)  $\frac{18V}{5}$   
 (c)  $\frac{5V}{9}$   
 (d)  $\frac{5V}{18}$

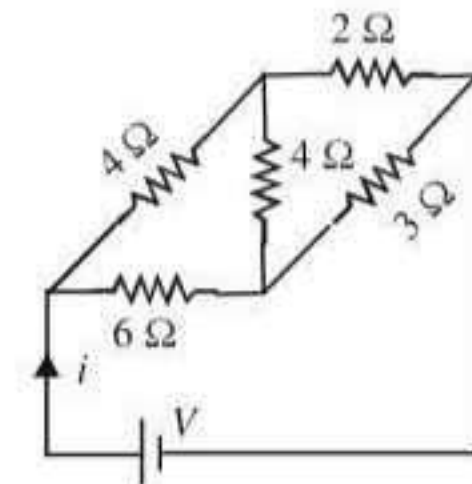

(2005)

50. A 5-ampere fuse wire can withstand a maximum power of 1 watt in the circuit. The resistance of the fuse wire is

- (a) 0.04 ohm (b) 0.2 ohm  
 (c) 5 ohm (d) 0.4 ohm.

(2005)

51. The electric resistance of a certain wire of iron is  $R$ . If its length and radius are both doubled, then

- (a) The resistance will be doubled and the specific resistance will be halved.  
 (b) The resistance will be halved and the specific resistance will remain unchanged.

- (c) The resistance will be halved and the specific resistance will be doubled.  
 (d) The resistance and the specific resistance, will both remain unchanged. (2004)
52. Resistance  $n$ , each of  $r$  ohm, when connected in parallel give an equivalent resistance of  $R$  ohm. If these resistances were connected in series, the combination would have a resistance in ohms, equal to  
 (a)  $n^2R$  (b)  $R/n^2$  (c)  $R/n$  (d)  $nR$  (2004)
53. Five equal resistances each of resistance  $R$  are connected as shown in the figure. A battery of  $V$  volts is connected between  $A$  and  $B$ . The current flowing in  $AFCEB$  will be

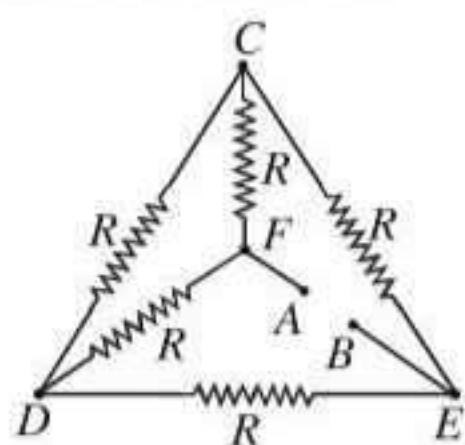

- (a)  $\frac{3V}{R}$  (b)  $\frac{V}{R}$  (c)  $\frac{V}{2R}$  (d)  $\frac{2V}{R}$  (2004)
54. A 6 volt battery is connected to the terminals of a three metre long wire of uniform thickness and resistance of 100 ohm. The difference of potential between two points on the wire separated by a distance of 50 cm will be  
 (a) 2 volt (b) 3 volt (c) 1 volt (d) 1.5 volt (2004)
55. When three identical bulbs of 60 watt, 200 volt rating are connected in series to a 200 volt supply, the power drawn by them will be  
 (a) 60 watt (b) 180 watt  
 (c) 10 watt (d) 20 watt (2004)
56. In India electricity is supplied for domestic use at 220 V. It is supplied at 110 V in USA. If the resistance of a 60 W bulb for use in India is  $R$ , the resistance of a 60 W bulb for use in USA will be  
 (a)  $R$  (b)  $2R$  (c)  $R/4$  (d)  $R/2$  (2004)
57. In a Wheatstone's bridge all the four arms have equal resistance  $R$ . If the resistance of the galvanometer arm is also  $R$ , the equivalent resistance of the combination as seen by the battery is  
 (a)  $R/4$  (b)  $R/2$  (c)  $R$  (d)  $2R$  (2003)
58. Two 220 volt, 100 watt bulbs are connected first in series and then in parallel. Each time the combination is connected to a 220 volt a.c. supply line. The power drawn by the combination in each case respectively will be  
 (a) 50 watt, 100 watt (b) 100 watt, 50 watt  
 (c) 200 watt, 150 watt (d) 50 watt, 200 watt (2003)
59. An electric kettle has two heating coils. When one of the coils is connected to an a.c. source, the water in the kettle boils in 10 minutes. When the other coil is used the water boils in 40 minutes. If both the coils are connected in parallel, the time taken by the same quantity of water to boil will be  
 (a) 8 minutes (b) 4 minutes  
 (c) 25 minutes (d) 15 minutes (2003)
60. Fuse wire is a wire of  
 (a) high resistance and high melting point  
 (b) high resistance and low melting point  
 (c) low resistance and low melting point  
 (d) low resistance and high melting point (2003)
61. For a cell terminal potential difference is 2.2 V when circuit is open and reduces to 1.8 V when cell is connected to a resistance of  $R = 5 \Omega$ . Determine internal resistance of cell ( $r$ )  
 (a)  $\frac{10}{9} \Omega$  (b)  $\frac{9}{10} \Omega$  (c)  $\frac{11}{9} \Omega$  (d)  $\frac{5}{9} \Omega$  (2002)
62. Specific resistance of a conductor increases with  
 (a) increase in temperature  
 (b) increase in cross-section area  
 (c) increase in cross-section and decrease in length  
 (d) decrease in cross-section area. (2002)
63. Copper and silicon is cooled from 300 K to 60 K, the specific resistance  
 (a) decrease in copper but increase in silicon  
 (b) increase in copper but decrease in silicon  
 (c) increase in both  
 (d) decrease in both. (2001)
64. The resistance of each arm of the Wheatstone's bridge is 10 ohm. A resistance of 10 ohm is

connected in series with a galvanometer then the equivalent resistance across the battery will be

- (a) 10 ohm (b) 15 ohm  
(c) 20 ohm (d) 40 ohm. (2001)

65. If specific resistance of a potentiometer wire is  $10^{-7} \Omega \text{ m}$  and current flow through it is 0.1 amp., cross-sectional area of wire is  $10^{-6} \text{ m}^2$  then potential gradient will be  
(a)  $10^{-2}$  volt/m (b)  $10^{-4}$  volt/m  
(c)  $10^{-6}$  volt/m (d)  $10^{-8}$  volt/m.

(2001)

66. The net resistance of the circuit between A and B is

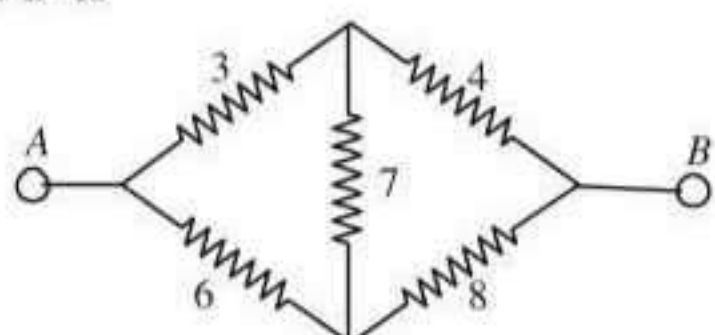

- (a)  $\frac{8}{3} \Omega$  (b)  $\frac{14}{3} \Omega$  (c)  $\frac{16}{3} \Omega$  (d)  $\frac{22}{3} \Omega$

(2000)

67. A car battery of emf 12 V and internal resistance  $5 \times 10^{-2} \Omega$ , receives a current of 60 amp. from external source, then terminal potential difference of battery is

- (a) 12 V (b) 9 V (c) 15 V (d) 20 V.

(2000)

68. Two bulbs of (40 W, 200 V) and (100 W, 200 V). Then correct relation for their resistances

- (a)  $R_{40} < R_{100}$  (b)  $R_{40} > R_{100}$

- (c)  $R_{40} = R_{100}$

- (d) no relation can be predicted. (2000)

69. The potentiometer is best for measuring voltage, as

- (a) it has a sensitive galvanometer and gives null deflection

- (b) it has wire of high resistance

- (c) it measures p.d. in closed circuit

- (d) it measures p.d. in open circuit. (2000)

70. The current in the given circuit is

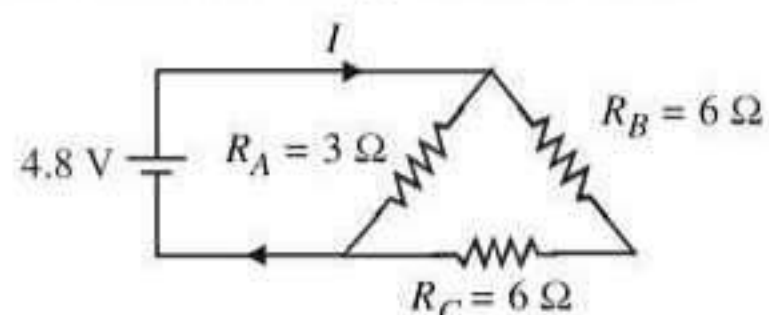

- (a) 4.9 A (b) 6.8 A (c) 8.3 A (d) 2.0 A

(1999)

71. The internal resistance of a cell of e.m.f. 2 V is  $0.1 \Omega$ . It is connected to a resistance of  $3.9 \Omega$ . The voltage across the cell will be

- (a) 1.95 V (b) 1.9 V (c) 0.5 V (d) 2 V

(1999)

72. In a meter bridge, the balancing length from the left end (standard resistance of one ohm is in the right gap) is found to be 20 cm. The value of the unknown resistance is

- (a)  $0.8 \Omega$  (b)  $0.5 \Omega$  (c)  $0.4 \Omega$  (d)  $0.25 \Omega$

(1999)

73. A potentiometer consists of a wire of length 4 m and resistance  $10 \Omega$ . It is connected to a cell of e.m.f. 2 V. The potential difference per unit length of the wire will be

- (a) 5 V/m (b) 2 V/m

- (c)  $0.5 \text{ V/m}$  (d) 10 V/m (1999)

74. The resistance of a discharge tube is

- (a) non-ohmic (b) ohmic

- (c) zero (d) both (b) and (c)

(1999)

75. Three equal resistors connected in series across a source of e.m.f. together dissipate 10 watt of power. What will be the power dissipated in watt if the same resistors are connected in parallel across the same source of e.m.f.?

- (a) 30 (b)  $\frac{10}{3}$  (c) 10 (d) 90

(1998)

76. A  $5^\circ\text{C}$  rise in temperature is observed in a conductor by passing a current. When the current is doubled the rise in temperature will be approximately

- (a)  $20^\circ\text{C}$  (b)  $16^\circ\text{C}$  (c)  $10^\circ\text{C}$  (d)  $12^\circ\text{C}$

(1998)

77. Three copper wires of lengths and cross-sectional areas are  $(l, A)$ ,  $(2l, A/2)$  and  $(l/2, 2A)$ . Resistance is minimum in

- (a) wire of cross-sectional area  $2A$

- (b) wire of cross-sectional area  $\frac{A}{2}$

- (c) wire of cross-sectional area  $A$

- (d) same in all three cases. (1997)

78. The current in the following circuit is

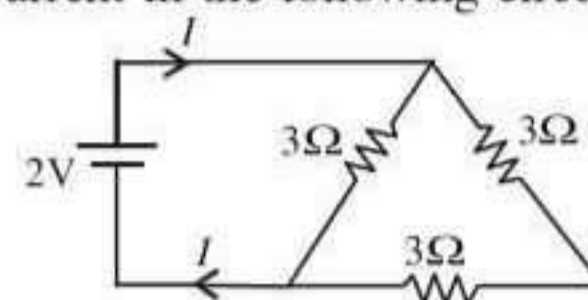

- (a)  $\frac{2}{3} \text{ A}$  (b) 1 A (c)  $\frac{1}{8} \text{ A}$  (d)  $\frac{2}{9} \text{ A}$ .

(1997)

79. Kirchhoff's first law, i.e.  $\Sigma i = 0$  at a junction, deals with the conservation of  
 (a) momentum (b) angular momentum  
 (c) charge (d) energy  
 (1997, 1992)

80. From the graph between current ( $I$ ) and voltage ( $V$ ) is shown below. Identify the portion corresponding to negative resistance

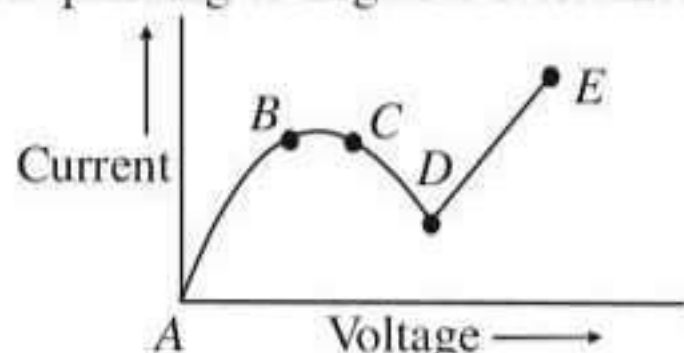

- (a) CD (b) DE (c) AB (d) BC  
 (1997)
81. A (100 W, 200 V) bulb is connected to a 160 volts supply. The power consumption would be  
 (a) 100 W (b) 125 W (c) 64 W (d) 80 W.  
 (1997)
82. One kilowatt hour is equal to  
 (a)  $36 \times 10^{-5}$  J (b)  $36 \times 10^{-4}$  J  
 (c)  $36 \times 10^5$  J (d)  $36 \times 10^3$  J (1997)
83. If two bulbs, whose resistances are in the ratio of 1 : 2 are connected in series, the power dissipated in them has the ratio of  
 (a) 2 : 1 (b) 1 : 4 (c) 1 : 1 (d) 1 : 2.  
 (1997)

84. What will be the equivalent resistance between the two points A and D?

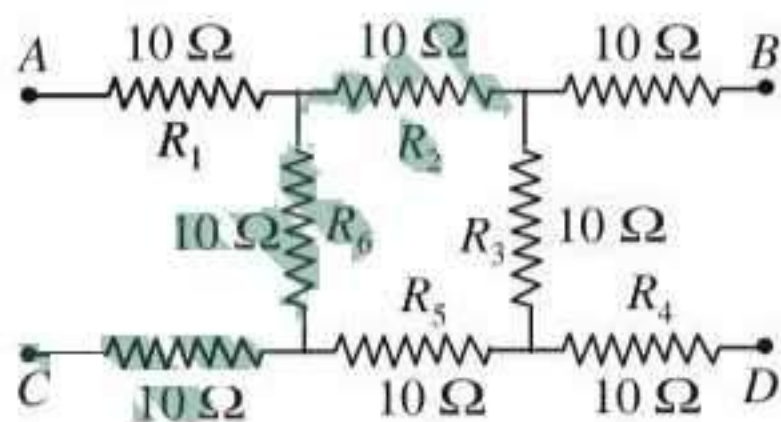

- (a) 30  $\Omega$  (b) 40  $\Omega$  (c) 10  $\Omega$  (d) 10  $\Omega$ .  
 (1996)
85. In the network shown in the figure, each of the resistance is equal to 2  $\Omega$ . The resistance between the points A and B is

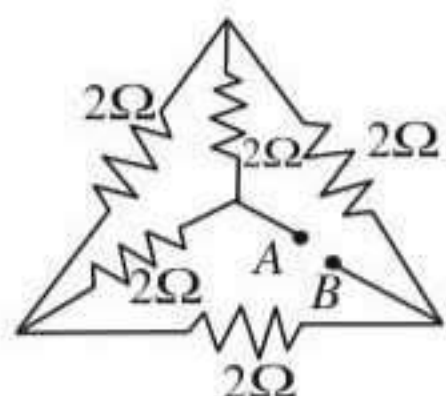

- (a) 3  $\Omega$  (b) 4  $\Omega$  (c) 1  $\Omega$  (d) 2  $\Omega$ .  
 (1995)

86. Two wires of the same metal have same length, but their cross-sections are in the ratio 3 : 1. They are joined in series. The resistance of thicker wire is 10  $\Omega$ . The total resistance of the combination will be  
 (a) 40  $\Omega$  (b) 100  $\Omega$   
 (c)  $(5/2)$   $\Omega$  (d)  $(40/3)$   $\Omega$ . (1995)

87. In good conductors of electricity, the type of bonding that exists is  
 (a) metallic (b) vander Waals  
 (c) ionic (d) covalent. (1995)

88. A heating coil is labelled 100 W, 220 V. The coil is cut in half and the two pieces are joined in parallel to the same source. The energy now liberated per second is  
 (a) 200 W (b) 400 W (c) 25 W (d) 50 W  
 (1995)

89. A 4  $\mu$ F capacitor is charged to 400 V. If its plates are joined through a resistance of 2 k $\Omega$ , then heat produced in the resistance is  
 (a) 0.64 J (b) 1.28 J (c) 0.16 J (d) 0.32 J  
 (1995)

90. A wire 50 cm long and 1 mm<sup>2</sup> in cross-section carries a current of 4 A when connected to a 2 V battery. The resistivity of the wire is  
 (a)  $4 \times 10^{-6}$   $\Omega$ m (b)  $1 \times 10^{-6}$   $\Omega$ m  
 (c)  $2 \times 10^{-7}$   $\Omega$ m (d)  $5 \times 10^{-7}$   $\Omega$ m.  
 (1994)

91. Six resistors of 3  $\Omega$  each are connected along the sides of a hexagon and three resistors of 6  $\Omega$  each are connected along AC, AD and AE as shown in the figure. The equivalent resistance between A and B is equal to

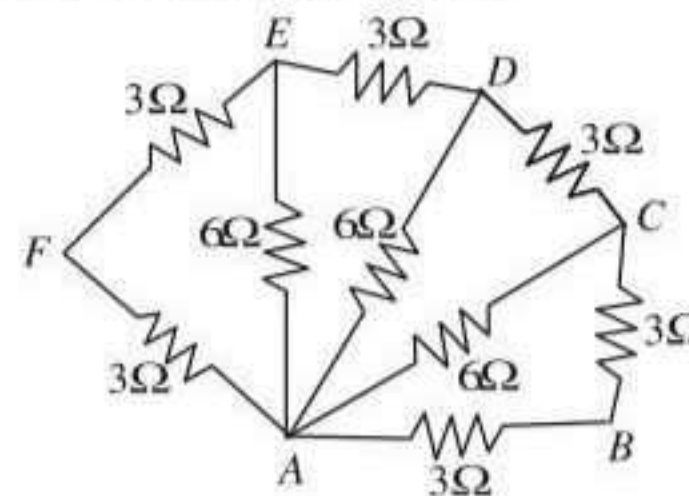

- (a) 2  $\Omega$  (b) 6  $\Omega$  (c) 3  $\Omega$  (d) 9  $\Omega$   
 (1994)

92. A flow of  $10^7$  electrons per second in a conducting wire constitutes a current of



- (a)  $1.6 \times 10^{-12}$  A      (b)  $1.6 \times 10^{26}$  A  
 (c)  $1.6 \times 10^{-26}$  A      (d)  $1.6 \times 10^{12}$  A.

(1994)

93. Identify the set in which all the three materials are good conductors of electricity  
 (a) Cu, Hg and NaCl  
 (b) Cu, Ge and Hg  
 (c) Cu, Ag and Au  
 (d) Cu, Si and diamond. (1994)
94. An electric bulb is rated 60 W, 220 V. The resistance of its filament is  
 (a) 870  $\Omega$       (b) 780  $\Omega$   
 (c) 708  $\Omega$       (d) 807  $\Omega$ . (1994)
95. Three resistances each of 4  $\Omega$  are connected to form a triangle. The resistance between any two terminals is  
 (a) 12  $\Omega$     (b) 2  $\Omega$     (c) 6  $\Omega$     (d)  $8/3$   $\Omega$  (1993)
96. Current through 3  $\Omega$  resistor is 0.8 ampere, then potential drop through 4  $\Omega$  resistor is

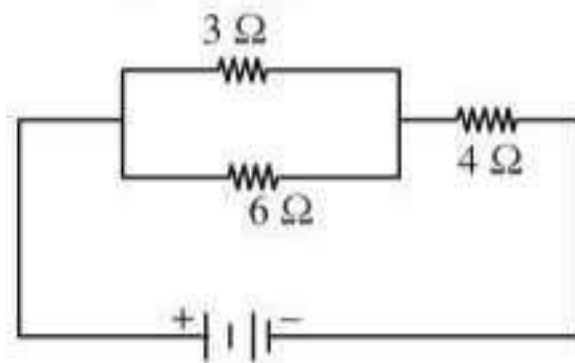

- (a) 9.6 V    (b) 2.6 V    (c) 4.8 V    (d) 1.2 V

(1993)

97. A battery of e.m.f 10 V and internal resistance 0.5  $\Omega$  is connected across a variable resistance  $R$ . The value of  $R$  for which the power delivered in it is maximum is given by  
 (a) 0.5  $\Omega$     (b) 1.0  $\Omega$     (c) 2.0  $\Omega$     (d) 0.25  $\Omega$  (1992)
98. The velocity of charge carriers of current (about 1 ampere) in a metal under normal conditions is of the order of  
 (a) a fraction of mm/sec  
 (b) velocity of light  
 (c) several thousand metres/second  
 (d) a few hundred metres per second (1991)
99. In the network shown in figure each resistance is 1  $\Omega$ . The effective resistance between  $A$  and  $B$  is

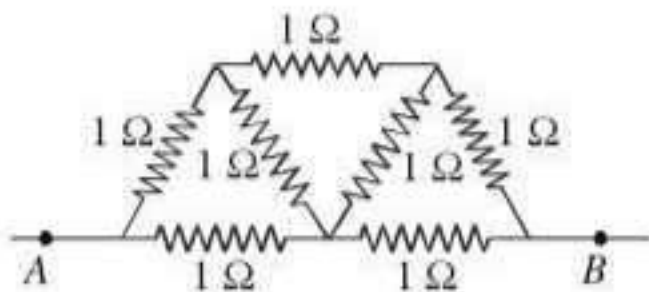

- (a)  $\frac{4}{3}$   $\Omega$     (b)  $\frac{3}{2}$   $\Omega$     (c) 7  $\Omega$     (d)  $\frac{8}{7}$   $\Omega$

(1990)

100. Two identical batteries each of e.m.f 2 V and internal resistance 1  $\Omega$  are available to produce heat in an external resistance by passing a current through it. The maximum power that can be developed across  $R$  using these batteries is  
 (a) 3.2 W      (b) 2.0 W  
 (c) 1.28 W      (d)  $\frac{8}{9}$  W (1990)
101. You are given several identical resistances each of value  $R = 10$   $\Omega$  and each capable of carrying a maximum current of one ampere. It is required to make a suitable combination of these resistances of 5  $\Omega$  which can carry a current of 4 ampere. The minimum number of resistances of the type  $R$  that will be required for this job is  
 (a) 4    (b) 10    (c) 8    (d) 20 (1990)

102. A current of 2 A, passing through a conductor produces 80 J of heat in 10 seconds. The resistance of the conductor in ohm is

- (a) 0.5    (b) 2    (c) 4    (d) 20

(1989)

103. 40 electric bulbs are connected in series across a 220 V supply. After one bulb is fused the remaining 39 are connected again in series across the same supply. The illumination will be  
 (a) more with 40 bulbs than with 39  
 (b) more with 39 bulbs than with 40  
 (c) equal in both the cases  
 (d) in the ratio  $40^2 : 39^2$  (1989)

104.  $n$  equal resistors are first connected in series and then connected in parallel. What is the ratio of the maximum to the minimum resistance?

- (a)  $n$     (b)  $1/n^2$     (c)  $n^2$     (d)  $1/n$

(1989)

105. Two batteries of emf 4 V and 8 V with internal resistance 1  $\Omega$  and 2  $\Omega$  are connected in a circuit with resistance of 9  $\Omega$  as shown in figure. The current and potential difference between the points  $P$  and  $Q$  are

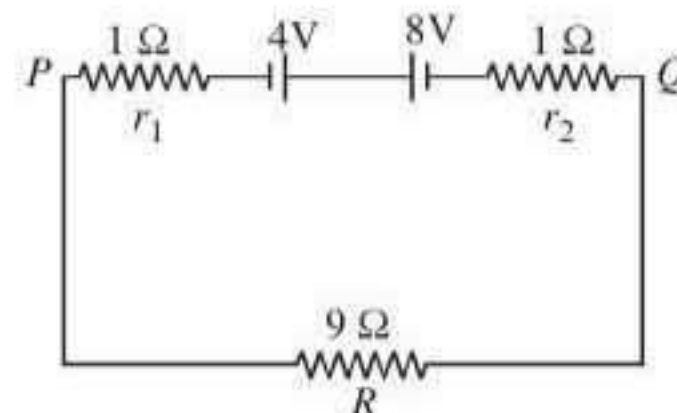

- (a)  $\frac{1}{3}$  A and 3 V  
 (b)  $\frac{1}{6}$  A and 4 V  
 (c)  $\frac{1}{9}$  A and 9 V  
 (d)  $\frac{1}{12}$  A and 12 V

(1988)

**106.** The masses of the wires of copper is in the ratio of 1 : 3 : 5 and their lengths are in the ratio of 5 : 3 : 1. The ratio of their electrical resistance is

- (a) 1 : 3 : 5  
 (b) 5 : 3 : 1  
 (c) 1 : 25 : 125  
 (d) 125 : 15 : 1

(1988)

---

**Answer Key**

---

- |          |          |          |          |          |          |         |         |         |          |
|----------|----------|----------|----------|----------|----------|---------|---------|---------|----------|
| 1. (b)   | 2. (b)   | 3. (d)   | 4. (c)   | 5. (b)   | 6. (c)   | 7. (c)  | 8. (c)  | 9. (d)  | 10. (c)  |
| 11. (d)  | 12. (c)  | 13. (b)  | 14. (b)  | 15. (c)  | 16. (d)  | 17. (d) | 18. (b) | 19. (d) | 20. (b)  |
| 21. (a)  | 22. (b)  | 23. (d)  | 24. (c)  | 25. (c)  | 26. (c)  | 27. (b) | 28. (c) | 29. (a) | 30. (d)  |
| 31. (b)  | 32. (d)  | 33. (d)  | 34. (a)  | 35. (c)  | 36. (b)  | 37. (d) | 38. (c) | 39. (c) | 40. (b)  |
| 41. (a)  | 42. (b)  | 43. (a)  | 44. (c)  | 45. (b)  | 46. (a)  | 47. (d) | 48. (a) | 49. (d) | 50. (a)  |
| 51. (b)  | 52. (a)  | 53. (c)  | 54. (c)  | 55. (d)  | 56. (c)  | 57. (c) | 58. (d) | 59. (a) | 60. (b)  |
| 61. (a)  | 62. (a)  | 63. (a)  | 64. (a)  | 65. (a)  | 66. (b)  | 67. (c) | 68. (b) | 69. (a) | 70. (d)  |
| 71. (a)  | 72. (d)  | 73. (c)  | 74. (a)  | 75. (d)  | 76. (a)  | 77. (a) | 78. (b) | 79. (c) | 80. (a)  |
| 81. (c)  | 82. (c)  | 83. (d)  | 84. (a)  | 85. (d)  | 86. (a)  | 87. (a) | 88. (b) | 89. (d) | 90. (b)  |
| 91. (a)  | 92. (a)  | 93. (c)  | 94. (d)  | 95. (d)  | 96. (c)  | 97. (a) | 98. (a) | 99. (d) | 100. (b) |
| 101. (c) | 102. (b) | 103. (b) | 104. (c) | 105. (a) | 106. (d) |         |         |         |          |
- 



## EXPLANATIONS

1. (b) : The resistance of a wire of length  $l$  and area  $A$  and resistivity  $\rho$  is given as

$$R = \frac{\rho l}{A}$$

Given,  $l' = nl$

As the volume of the wire remains constant

$$\therefore A'l' = Al$$

$$A' = \frac{Al}{l'} = \frac{Al}{nl} \text{ or } A' = \frac{A}{n}$$

$$\therefore R' = \frac{\rho l'}{A'}$$

$$R' = \frac{\rho nl}{\frac{A}{n}} = \frac{n^2 \rho l}{A} = n^2 R$$

2. (b) : A potentiometer is an accurate and versatile device to make electrical measurements of emf because the method involves a condition of no current flow through the galvanometer, the device can be used to measure potential difference, internal resistance of a cell and compare emf's of two sources.

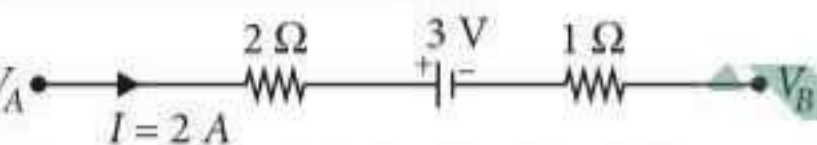
3. (d) : 

$$V_{AB} = V_A - V_B = 2 \times 2 + 3 + 1 \times 2 = 9 \text{ V}$$

4. (c) : Resistance of bulb,  $R_B = \frac{V^2}{P} = \frac{(100)^2}{500} = 20 \Omega$

Power of the bulb in the circuit,

$$P = VI$$

$$I = \frac{P}{V_B}$$

$$= \frac{500}{100} = 5 \text{ A}$$

$$V_R = IR \Rightarrow (230 - 100) = 5 \times R$$

$$\therefore R = 26 \Omega$$

5. (b) : Suppose two cells have emfs  $\epsilon_1$  and  $\epsilon_2$  (also  $\epsilon_1 > \epsilon_2$ ).

Potential difference per unit length of the potentiometer wire =  $k$  (say)

When  $\epsilon_1$  and  $\epsilon_2$  are in series and support each other then

$$\epsilon_1 + \epsilon_2 = 50 \times k \quad \dots \text{(i)}$$

When  $\epsilon_1$  and  $\epsilon_2$  are in opposite direction

$$\epsilon_1 - \epsilon_2 = 10 \times k \quad \dots \text{(ii)}$$

On adding eqn. (i) and eqn. (ii)

$$2\epsilon_1 = 60k \Rightarrow \epsilon_1 = 30k \text{ and } \epsilon_2 = 50k - 30k = 20k$$

$$\therefore \frac{\epsilon_1}{\epsilon_2} = \frac{30k}{20k} = \frac{3}{2}$$

6. (c) : Given,  $Q = at - bt^2$

$$\therefore I = \frac{dQ}{dt} = a - 2bt$$

At  $t = 0$ ,  $Q = 0 \Rightarrow I = 0$

Also,  $I = 0$  at  $t = a/2b$

$\therefore$  Total heat produced in resistance  $R$ ,

$$H = \int_0^{a/2b} I^2 R dt = R \int_0^{a/2b} (a - 2bt)^2 dt$$

$$= R \int_0^{a/2b} (a^2 + 4b^2 t^2 - 4abt) dt$$

$$= R \left[ a^2 t + 4b^2 \frac{t^3}{3} - 4ab \frac{t^2}{2} \right]_0^{a/2b}$$

$$= R \left[ a^2 \times \frac{a}{2b} + \frac{4b^2}{3} \times \frac{a^3}{8b^3} - \frac{4ab}{2} \times \frac{a^2}{4b^2} \right]$$

$$= \frac{a^3 R}{b} \left[ \frac{1}{2} + \frac{1}{6} - \frac{1}{2} \right] = \frac{a^3 R}{6b}$$

7. (c) : As both metal wires are of identical dimensions, so their length and area of cross-section will be same. Let them be  $l$  and  $A$  respectively. Then The resistance of the first wire is

$$R_1 = \frac{l}{\sigma_1 A} \quad \dots \text{(i)}$$

and that of the second wire is

$$R_2 = \frac{l}{\sigma_2 A} \quad \dots \text{(ii)}$$

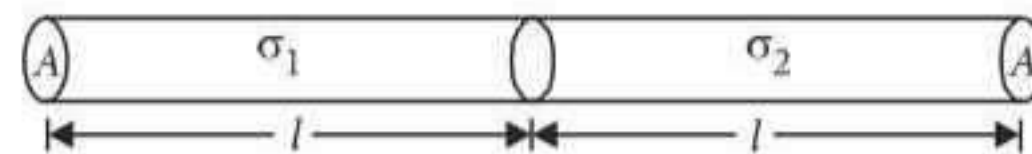

As they are connected in series, so their effective resistance is

$$R_s = R_1 + R_2 = \frac{l}{\sigma_1 A} + \frac{l}{\sigma_2 A} \quad \text{(using (i) and (ii))}$$

$$= \frac{l}{A} \left( \frac{1}{\sigma_1} + \frac{1}{\sigma_2} \right) \quad \dots \text{(iii)}$$

If  $\sigma_{\text{eff}}$  is the effective conductivity of the combination, then

$$R_s = \frac{2l}{\sigma_{\text{eff}} A} \quad \dots \text{(iv)}$$

Equating eqns. (iii) and (iv), we get

$$\frac{2l}{\sigma_{\text{eff}} A} = \frac{l}{A} \left( \frac{1}{\sigma_1} + \frac{1}{\sigma_2} \right)$$

$$\frac{2}{\sigma_{\text{eff}}} = \frac{\sigma_2 + \sigma_1}{\sigma_1 \sigma_2} \quad \text{or} \quad \sigma_{\text{eff}} = \frac{2\sigma_1 \sigma_2}{\sigma_1 + \sigma_2}$$

8. (c) : The circuit is shown in the figure.

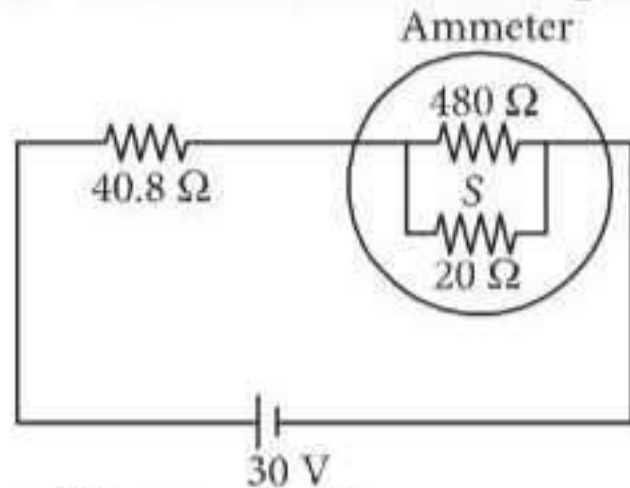

Resistance of the ammeter is

$$R_A = \frac{(480 \Omega)(20 \Omega)}{(480 \Omega + 20 \Omega)} = 19.2 \Omega$$

(As 480  $\Omega$  and 20  $\Omega$  are in parallel)

As ammeter is in series with 40.8  $\Omega$ ,

$\therefore$  Total resistance of the circuit is

$$R = 40.8 \Omega + R_A = 40.8 \Omega + 19.2 \Omega = 60 \Omega$$

By Ohm's law,

Current in the circuit is

$$I = \frac{V}{R} = \frac{30 \text{ V}}{60 \Omega} = \frac{1}{2} \text{ A} = 0.5 \text{ A}$$

Thus the reading in the ammeter will be 0.5 A.

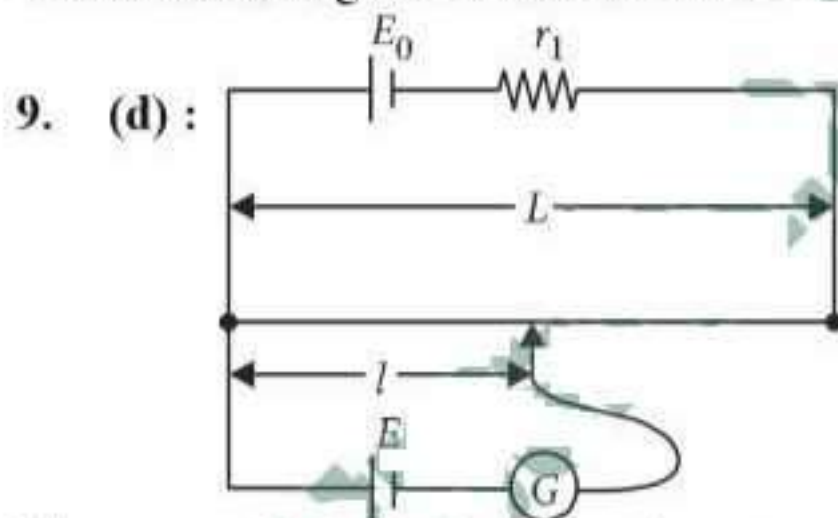

The current through the potentiometer wire is

$$I = \frac{E_0}{(r + r_1)}$$

and the potential difference across the wire is

$$V = Ir = \frac{E_0 r}{(r + r_1)}$$

The potential gradient along the potentiometer wire is

$$k = \frac{V}{L} = \frac{E_0 r}{(r + r_1)L}$$

As the unknown e.m.f.  $E$  is balanced against length  $l$  of the potentiometer wire,

$$\therefore E = kl = \frac{E_0 r}{(r + r_1)} \frac{l}{L}$$

10. (c) : The current flowing in the different branches of circuit is indicated in the figure.

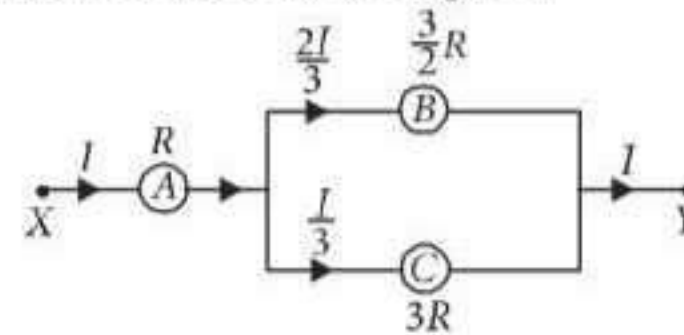

$$V_A = IR$$

$$V_B = \frac{2I}{3} \times \frac{3}{2} R = IR$$

$$V_C = \frac{I}{3} \times 3R = IR$$

Thus,  $V_A = V_B = V_C$

11. (d) : The area of cross section of conductor is non uniform so current density will be different but the flow of electrons will be uniform so current will be constant.

12. (c) : Required potential gradient = 1 mV cm<sup>-1</sup>

$$= \frac{1}{10} \text{ V m}^{-1}$$

Length of potentiometer wire,  $l = 4 \text{ m}$

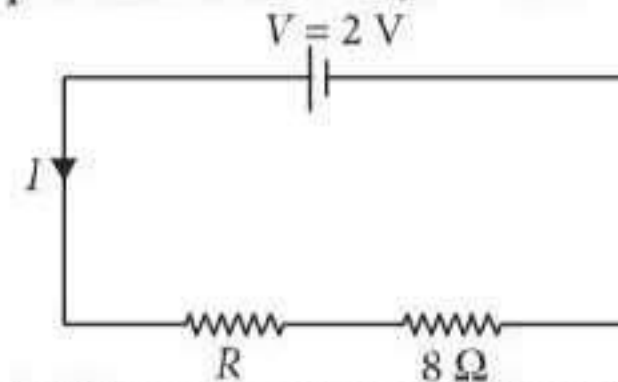

So potential difference across potentiometer wire

$$= \frac{1}{10} \times 4 = 0.4 \text{ V} \quad \dots (i)$$

In the circuit, potential difference across 8  $\Omega$

$$= I \times 8 = \frac{2}{8 + R} \times 8 \quad \dots (ii)$$

Using equation (i) and (ii), we get,  $0.4 = \frac{2}{8 + R} \times 8$

$$\frac{4}{10} = \frac{16}{8 + R}, 8 + R = 40$$

$\therefore R = 32 \Omega$

13. (b) : In the first case,

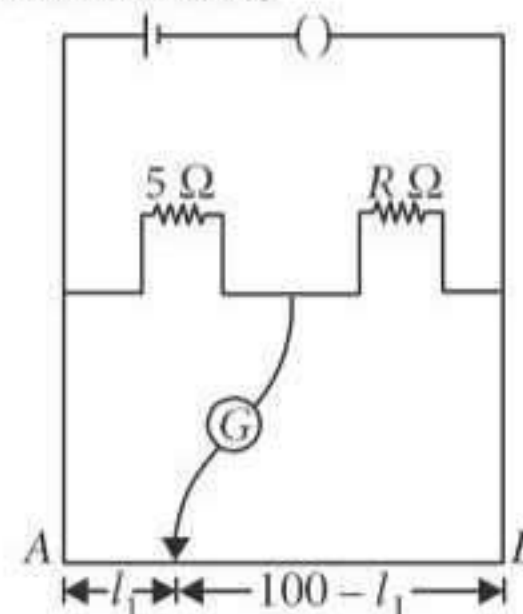

At balance point

$$\frac{5}{R} = \frac{l_1}{100 - l_1} \quad \dots(i)$$

In the second case,

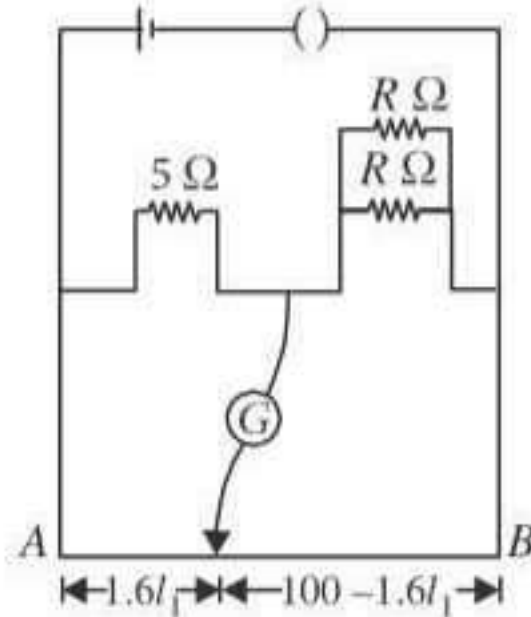

At balance point

$$\frac{5}{(R/2)} = \frac{1.6l_1}{100 - 1.6l_1} \quad \dots(ii)$$

Divide eqn. (i) by eqn. (ii), we get

$$\frac{1}{2} = \frac{100 - 1.6l_1}{1.6(100 - l_1)}$$

$$160 - 1.6l_1 = 200 - 3.2l_1$$

$$1.6l_1 = 40 \quad \text{or} \quad l_1 = \frac{40}{1.6} = 25 \text{ cm}$$

Substituting this value in eqn. (i), we get

$$\frac{5}{R} = \frac{25}{75}$$

$$R = \frac{375}{25} \Omega = 15 \Omega$$

14. (b) : Here,

Distance between two cities = 150 km

Resistance of the wire,  $R = (0.5 \Omega \text{ km}^{-1})(150 \text{ km}) = 75 \Omega$

Voltage drop across the wire,

$$V = (8 \text{ V km}^{-1})(150 \text{ km}) = 1200 \text{ V}$$

Power loss in the wire is

$$P = \frac{V^2}{R} = \frac{(1200 \text{ V})^2}{75 \Omega} = 19200 \text{ W} = 19.2 \text{ kW}$$

15. (c) : The internal resistance of the cell is

$$r = \left( \frac{l_1}{l_2} - 1 \right) R$$

Here,  $l_1 = 3 \text{ m}$ ,  $l_2 = 2.85 \text{ m}$ ,  $R = 9.5 \Omega$

$$\therefore r = \left( \frac{3}{2.85} - 1 \right) (9.5 \Omega) = \frac{0.15}{2.85} \times 9.5 \Omega = 0.5 \Omega$$

16. (d) : The situation is as shown in the figure.

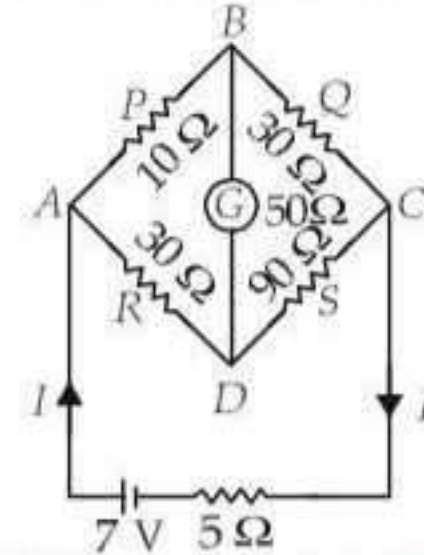

For a balanced Wheatstone's bridge

$$\frac{P}{Q} = \frac{R}{S}$$

$$\therefore \frac{10 \Omega}{30 \Omega} = \frac{30 \Omega}{90 \Omega} \quad \text{or} \quad \frac{1}{3} = \frac{1}{3}$$

It is a balanced Wheatstone's bridge. Hence no current flows in the galvanometer arm. Hence, resistance  $50 \Omega$  becomes ineffective.

$\therefore$  The equivalent resistance of the circuit is

$$\begin{aligned} R_{\text{eq}} &= 5 \Omega + \frac{(10 \Omega + 30 \Omega)(30 \Omega + 90 \Omega)}{(10 \Omega + 30 \Omega) + (30 \Omega + 90 \Omega)} \\ &= 5 \Omega + \frac{(40 \Omega)(120 \Omega)}{40 \Omega + 120 \Omega} = 5 \Omega + 30 \Omega = 35 \Omega \end{aligned}$$

Current drawn from the cell is

$$I = \frac{7 \text{ V}}{35 \Omega} = \frac{1}{5} \text{ A} = 0.2 \text{ A}$$

17. (d) :  $I = \frac{\epsilon}{R+r}$

or  $IR + Ir = \epsilon$

Here,  $R = 10 \Omega$ ,  $r = ?$ ,

$$\epsilon = 2.1 \text{ V}, I = 0.2 \text{ A}$$

$$\therefore 0.2 \times 10 + 0.2 \times r = 2.1$$

$$2 + 0.2r = 2.1$$

$$0.2r = 0.1 \quad \text{or} \quad r = \frac{1}{2} = 0.5 \Omega$$

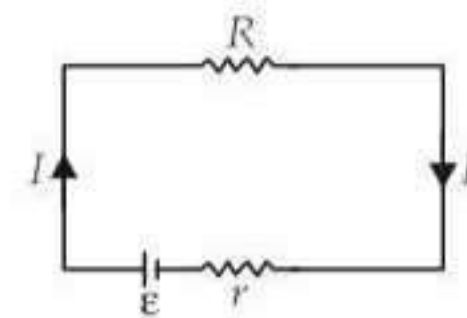

18. (b) : Resistance of a wire,  $R = \rho \frac{l}{A} = 4 \Omega \quad \dots(i)$

When wire is stretched twice, its new length be  $l'$ . Then

$$l' = 2l$$

On stretching volume of the wire remains constant.

$\therefore lA = l'A'$  where  $A'$  is the new cross-sectional area

$$\text{or} \quad A' = \frac{l}{l'} A = \frac{l}{2l} A = \frac{A}{2}$$

$\therefore$  Resistance of the stretched wire is

$$R' = \rho \frac{l'}{A'} = \rho \frac{2l}{(A/2)} = 4\rho \frac{l}{A}$$

$$= 4(4 \Omega) = 16 \Omega$$

(Using (i))

19. (d) : Here,

Length of each rod,  $l = 1 \text{ m}$

Area of cross-section of each rod,

$$A = 0.01 \text{ cm}^2 = 0.01 \times 10^{-4} \text{ m}^2$$

Resistivity of copper rod,

$$\begin{aligned} \rho_{\text{Cu}} &= 1.7 \times 10^{-6} \Omega \text{ cm} \\ &= 1.7 \times 10^{-6} \times 10^{-2} \Omega \text{ m} = 1.7 \times 10^{-8} \Omega \text{ m} \end{aligned}$$

Resistivity of iron rod,

$$\begin{aligned} \rho_{\text{Fe}} &= 10^{-5} \Omega \text{ cm} \\ &= 10^{-5} \times 10^{-2} \Omega \text{ m} = 10^{-7} \Omega \text{ m} \end{aligned}$$

∴ Resistance of copper rod,

$$R_{\text{Cu}} = \rho_{\text{Cu}} \frac{l}{A}$$

and resistance of iron rod,  $R_{\text{Fe}} = \rho_{\text{Fe}} \frac{l}{A}$

As copper and iron rods are connected in series, therefore equivalent resistance is

$$R = R_{\text{Cu}} + R_{\text{Fe}} = \rho_{\text{Cu}} \frac{l}{A} + \rho_{\text{Fe}} \frac{l}{A} = (\rho_{\text{Cu}} + \rho_{\text{Fe}}) \frac{l}{A}$$

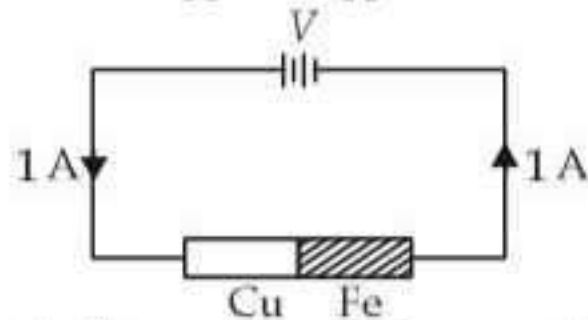

Voltage required to produce 1 A current in the rods is

$$\begin{aligned} V &= IR = (1)(R_{\text{Cu}} + R_{\text{Fe}}) \\ &= (\rho_{\text{Cu}} + \rho_{\text{Fe}}) \left( \frac{l}{A} \right) \\ &= (1.7 \times 10^{-8} + 10^{-7}) \left( \frac{1}{0.01 \times 10^{-4}} \right) \text{ V} \\ &= 10^{-7} (0.17 + 1) (10^6) \text{ V} = 1.17 \times 10^{-1} \text{ V} = 0.117 \text{ V} \end{aligned}$$

20. (b) : Let  $\rho$  and  $A$  be resistivity and area of cross-section of the wire respectively.

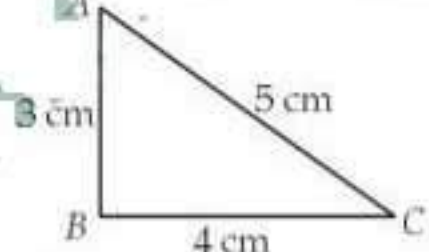

The wire is bent in the form of right triangle as shown in adjacent figure.

Resistance of side AB is  $R_1 = \frac{3\rho}{A}$

Resistance of side BC is  $R_2 = \frac{4\rho}{A}$

Resistance of side AC is  $R_3 = \frac{5\rho}{A}$

∴ The resistance between the ends A and B is

$$R_{AB} = \frac{R_1(R_2 + R_3)}{R_1 + R_2 + R_3} = \frac{\frac{3\rho}{A} \left( \frac{4\rho}{A} + \frac{5\rho}{A} \right)}{\frac{3\rho}{A} + \left( \frac{4\rho}{A} + \frac{5\rho}{A} \right)} = \frac{27 \rho}{12 A}$$

The resistance between the ends B and C is

$$R_{BC} = \frac{R_2(R_1 + R_3)}{R_2 + R_1 + R_3} = \frac{\frac{4\rho}{A} \left( \frac{3\rho}{A} + \frac{5\rho}{A} \right)}{\frac{4\rho}{A} + \frac{3\rho}{A} + \frac{5\rho}{A}} = \frac{32 \rho}{12 A}$$

The resistance between the ends A and C is

$$R_{AC} = \frac{R_3(R_1 + R_2)}{R_3 + R_1 + R_2} = \frac{\frac{5\rho}{A} \left( \frac{3\rho}{A} + \frac{4\rho}{A} \right)}{\frac{5\rho}{A} + \frac{3\rho}{A} + \frac{4\rho}{A}} = \frac{35 \rho}{12 A}$$

$$\therefore R_{AB} : R_{BC} : R_{AC} = \frac{27}{12} : \frac{32}{12} : \frac{35}{12} = 27 : 32 : 35$$

21. (a) : Let  $\rho$  be resistivity of the material of the wire and  $r$  be radius of the wire.

Therefore, resistance of 1 m wire is

$$R = \frac{\rho(1)}{\pi r^2} = \frac{\rho}{\pi r^2} \quad \left( \because R = \frac{\rho l}{A} \right)$$

Let  $\epsilon$  be emf of each cell.

In first case,

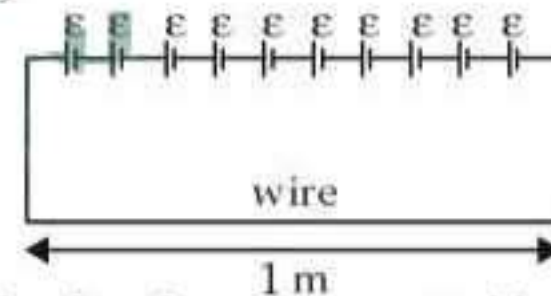

10 cells each of emf  $\epsilon$  are connected in series to heat the wire of length 1 m by  $\Delta T (= 10^\circ\text{C})$  in time  $t$ .

$$\therefore \frac{(10\epsilon)^2}{R} t = ms\Delta T \quad \dots (i)$$

In second case,

Resistance of same wire of length 2 m is

$$R' = \frac{\rho(2)}{\pi r^2} = \frac{2\rho}{\pi r^2} = 2R$$

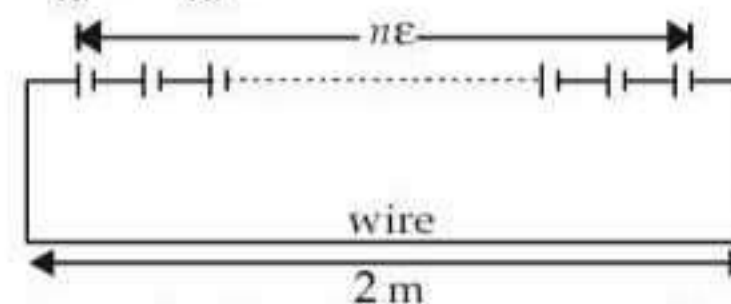

Let  $n$  cells each of emf  $\epsilon$  are connected in series to heat the same wire of length 2 m, by the same temperature  $\Delta T (= 10^\circ\text{C})$  in the same time  $t$ .

$$\therefore \frac{(n\epsilon)^2}{2R} t = (2m)s\Delta T \quad \dots (ii)$$

Divide (ii) by (i), we get

$$\frac{n^2}{200} = 2 \Rightarrow n^2 = 400 \quad \therefore n = 20$$

22. (b) : Since the galvanometer shows no deflection so current will flow as shown in the figure.

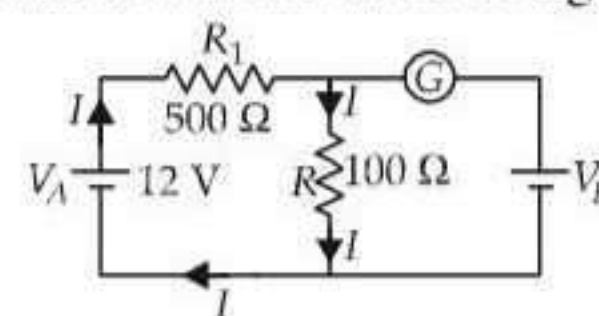

$$\text{Current, } I = \frac{V_A}{R_1 + R} = \frac{12 \text{ V}}{(500 + 100) \Omega} = \frac{12}{600} \text{ A}$$

$$V_B = IR = \left(\frac{12}{600} \text{ A}\right)(100 \Omega) = 2 \text{ V}$$

**23. (d) :** Let  $x$  be resistance per unit length of the wire. Then,

The resistance of the upper portion is

$$R_1 = xl_1$$

The resistance of the lower portion is

$$R_2 = xl_2$$

Equivalent resistance between  $A$  and  $B$  is

$$R = \frac{R_1 R_2}{R_1 + R_2} = \frac{(xl_1)(xl_2)}{xl_1 + xl_2}$$

$$\frac{8}{3} = \frac{xl_1 l_2}{l_1 + l_2} \quad \text{or} \quad \frac{8}{3} = \frac{xl_1 l_2}{l_2 \left(\frac{l_1}{l_2} + 1\right)} \quad \text{or} \quad \frac{8}{3} = \frac{xl_1}{\left(\frac{l_1}{l_2} + 1\right)} \quad \dots(i)$$

Also  $R_0 = xl_1 + xl_2$   
 $12 = x(l_1 + l_2)$   
 $12 = xl_2 \left(\frac{l_1}{l_2} + 1\right)$  ... (ii)

Divide (i) by (ii), we get

$$\frac{\frac{8}{3}}{12} = \frac{\frac{xl_1}{\left(\frac{l_1}{l_2} + 1\right)}}{xl_2 \left(\frac{l_1}{l_2} + 1\right)} \quad \text{or} \quad \frac{8}{36} = \frac{l_1}{l_2 \left(\frac{l_1}{l_2} + 1\right)^2}$$

$$\left(\frac{l_1}{l_2} + 1\right)^2 \frac{8}{36} = \frac{l_1}{l_2} \quad \text{or} \quad \left(\frac{l_1}{l_2} + 1\right)^2 \frac{2}{9} = \frac{l_1}{l_2}$$

$$\text{Let } y = \frac{l_1}{l_2}$$

$$\therefore 2(y+1)^2 = 9y \quad \text{or} \quad 2y^2 + 2 + 4y = 9y$$

$$\text{or} \quad 2y^2 - 5y + 2 = 0$$

Solving this quadratic equation, we get

$$y = \frac{1}{2} \quad \text{or} \quad 2 \quad \therefore \frac{l_1}{l_2} = \frac{1}{2}$$

**24. (c) :** Power,  $P = \frac{V^2}{R}$

As the resistance of the bulb is constant

$$\therefore \frac{\Delta P}{P} = \frac{2\Delta V}{V}$$

$$\% \text{ decrease in power} = \frac{\Delta P}{P} \times 100 = \frac{2\Delta V}{V} \times 100$$

$$= 2 \times 2.5\% = 5\%$$

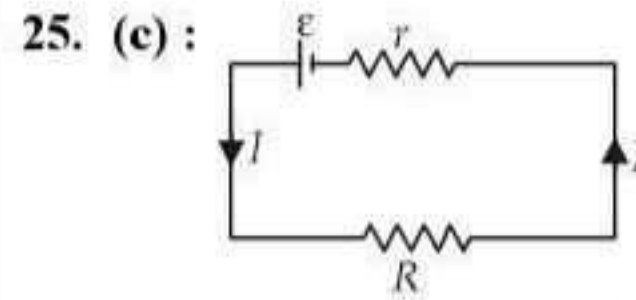

$$\text{Current in the circuit, } I = \frac{\epsilon}{R+r}$$

Potential difference across  $R$ ,

$$V = IR = \left(\frac{\epsilon}{R+r}\right)R$$

$$V = \frac{\epsilon}{1 + \frac{r}{R}}$$

When  $R = 0$ ,  $V = 0$

$$R = \infty, V = \epsilon$$

Hence, option (c) represents the correct graph.

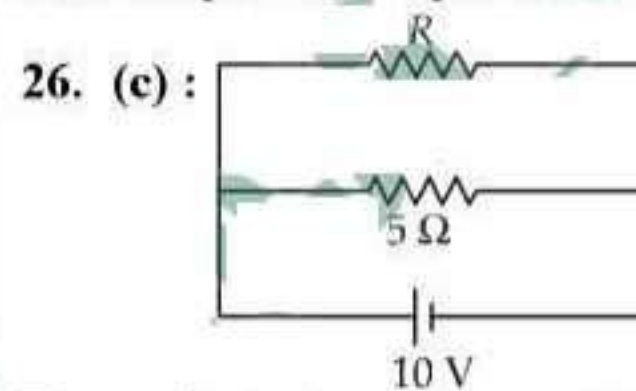

The equivalent resistance of the given circuit is

$$R_{\text{eq}} = \frac{5R}{5+R}$$

Power dissipated in the given circuit is

$$P = \frac{V^2}{R_{\text{eq}}} \quad \text{or} \quad 30 = \frac{(10)^2}{\left(\frac{5R}{5+R}\right)}$$

$$150R = 100(5+R)$$

$$150R = 500 + 100R \quad \text{or} \quad 50R = 500$$

$$R = \frac{500}{50} = 10 \Omega$$

**27. (b) :** Let  $\epsilon$  be the emf and  $r$  be internal resistance of the battery.

In the first case,

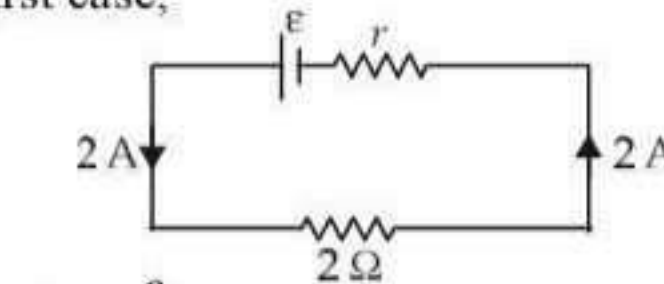

$$2 = \frac{\epsilon}{2+r} \quad \dots(i)$$

In the second case,

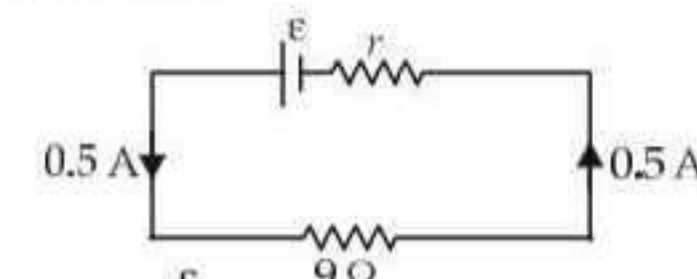

$$0.5 = \frac{\epsilon}{9+r} \quad \dots(ii)$$

Divide (i) by (ii), we get

$$\frac{2}{0.5} = \frac{9+r}{2+r} \Rightarrow 4 + 2r = 4.5 + 0.5r$$

$$1.5r = 0.5 \Rightarrow r = \frac{0.5}{1.5} = \frac{1}{3} \Omega$$

28. (c) :

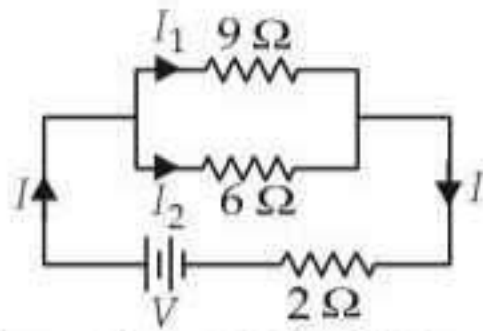

Current flows through the 9 Ω resistor is

$$I_1^2 = \frac{36}{9} = 4 \quad (\text{As } P = I^2R)$$

$$I_1 = 2 \text{ A}$$

As the resistors 9 Ω and 6 Ω are connected in parallel, therefore potential difference across them is same.

$$\therefore 9I_1 = 6I_2$$

$$I_2 = \frac{9 \times 2}{6} = 3 \text{ A}$$

Current drawn from the battery is

$$I = I_1 + I_2 = (2 + 3) \text{ A} = 5 \text{ A}$$

The potential difference across the 2 Ω resistor is  
 $= (5 \text{ A})(2 \Omega) = 10 \text{ V}$

29. (a) :

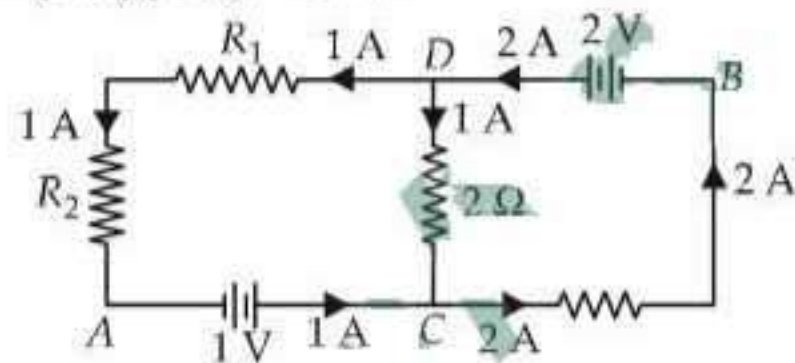

Applying Kirchhoff voltage law in the circuit as shown in the figure below.

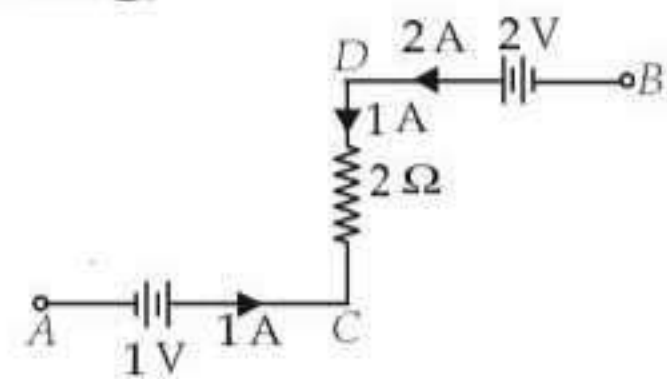

$$\therefore V_A + 1 + 2(1) - 2 = V_B$$

$$0 + 1 = V_B \quad (\because V_A = 0 \text{ V (Given)})$$

$$V_B = +1 \text{ V}$$

30. (d) : Kirchhoff's junction law or Kirchhoff's first law is based on the conservation of charge.

Kirchhoff's loop law or Kirchhoff's second law is based on the conservation of energy.

Hence both statements (A) and (B) are correct.

31. (b) :

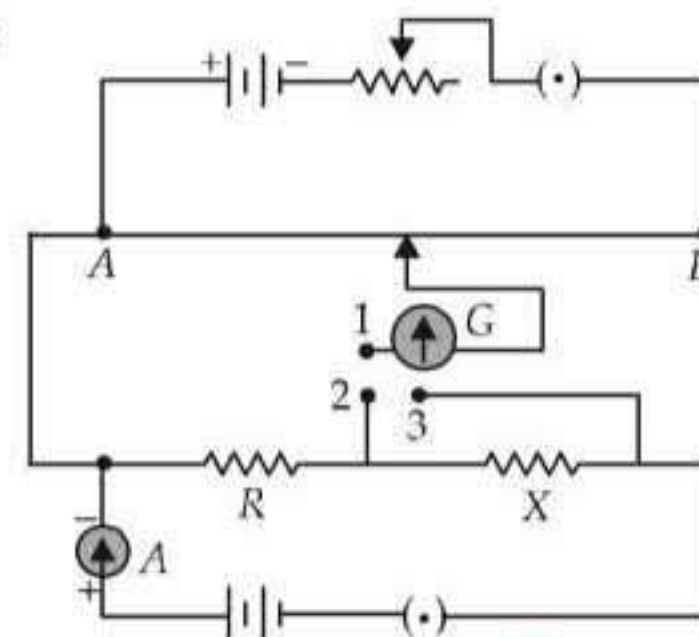

When the two way key is switched off, then

The current flowing in the resistors R and X is

$$I = 1 \text{ A} \quad \dots(i)$$

When the key between the terminals 1 and 2 is plugged in, then

$$\text{Potential difference across } R = IR = kl_1 \quad \dots(ii)$$

where  $k$  is the potential gradient across the potentiometer wire

When the key between the terminals 1 and 3 is plugged in, then

$$\text{Potential difference across } (R + X) = I(R + X) = kl_2 \quad \dots(iii)$$

From equation (ii), we get

$$R = \frac{kl_1}{I} = \frac{kl_1}{1} = kl_1 \Omega \quad \dots(iv)$$

From equation (iii), we get

$$R + X = \frac{kl_2}{I} = \frac{kl_2}{1} = kl_2 \Omega \quad (\text{Using (i)})$$

$$X = kl_2 - R$$

$$= kl_2 - kl_1$$

$$= k(l_2 - l_1) \Omega$$

(Using (iv))

32. (d) :

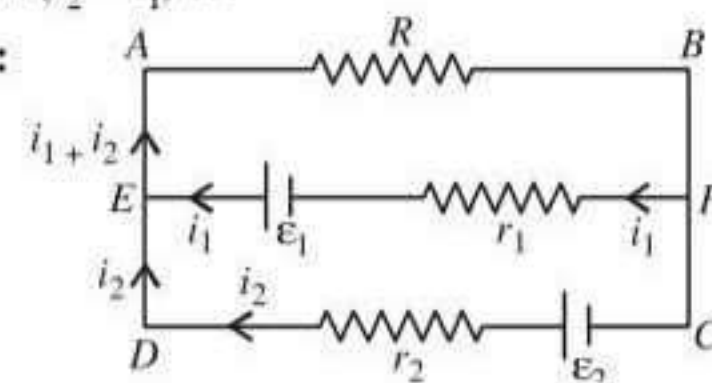

Applying Kirchhoff's equation to the loop ABFE,

$$-(i_1 + i_2)R - i_1 r_1 + \epsilon_1 = 0$$

$$\text{or } \epsilon_1 - (i_1 + i_2)R - i_1 r_1 = 0.$$

33. (d) : Wire of length  $2\pi \times 0.1 \text{ m}$  of  $12 \Omega/\text{m}$  is bent to a circle.

Resistance of each part

$$= 12 \times \pi \times 0.1 = 1.2\pi \Omega$$

$\therefore$  Resistance between A and B =  $0.6\pi \Omega$ .

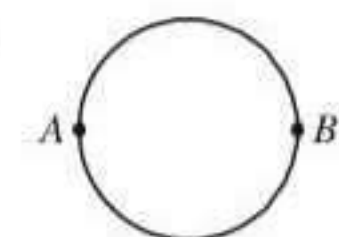

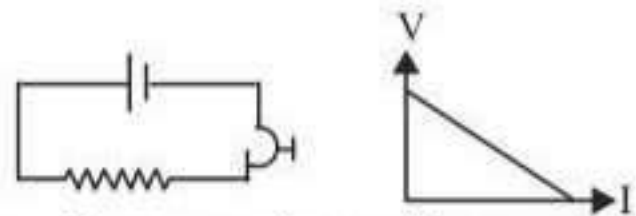

34. (a) : 

$V = \epsilon - Ir$ , comparing with  $y = c - mx$

∴ Slope =  $-r$ , internal resistance.

$V_{\max} = \text{emf } \epsilon$ . This is intercept on the y-axis.

∴ Slope is negative.

∴  $I$  decreases as  $R$  increases.

35. (c) : Energy =  $2 \text{ eV} = eE\lambda$

∴  $E = \frac{2eV}{e\lambda} = \frac{2}{4 \times 10^{-8}} = 5 \times 10^7 \text{ V/m}$ .

36. (b) : As the P.D. between  $4 \Omega$  and  $3 \Omega$  (in parallel), are the same,

$$4 \times 1 \text{ amp} = 3 \times i_1 \Rightarrow i_1 = \frac{4}{3} \text{ A}$$

Total resistance of  $4 \Omega$  and  $3 \Omega = 12/7 \Omega$ .

Current in  $MQP$  (upper one) =  $1 + \frac{4}{3} = \frac{7}{3} \text{ A}$

∴ P.D. =  $\frac{12}{7} \times \frac{7}{3} = 4 \text{ V}$

Current in  $MNP = \frac{4}{1.25} = \frac{4 \times 4}{5} = \frac{16}{5} \text{ A}$

∴ P.D. across  $1 \Omega = \frac{16}{5} \text{ A} \times 1 \Omega = \frac{16}{5} \text{ volt}$

⇒ P.D. across  $1 \Omega = 3.2 \text{ volt}$ .

37. (d) :  $\frac{\Delta l}{l} = 0.1 \quad \therefore l = 1.1$

but the area also decreases by  $0.1$ .  
mass =  $\rho l A = V \rho$ .  $\ln l + \ln A = \ln \text{mass}$ .

∴  $\frac{\Delta l}{l} + \frac{\Delta A}{A} = 0 \Rightarrow \frac{\Delta l}{l} = -\frac{\Delta A}{A}$

Length increases by  $0.1$ , resistance increases, area decreases by  $0.1$ , then also resistance will increase. Total increase in resistance is approximately 1.2 times, due to increase in length and decrease in area. But specific resistance does not change.

38. (c) : [In the question, the length  $110 \text{ cm}$  &  $100$

cm are interchanged ] as  $\epsilon > \frac{\epsilon R}{R+r}$

Without being short circuited through  $R$ , only the battery  $\epsilon$  is balanced.

$$\epsilon = \frac{V}{L} \times l_1 = \frac{V}{L} \times 110 \text{ cm} \quad \dots(i)$$

When  $R$  is connected across  $\epsilon$ ,

$$Ri = R \cdot \left( \frac{\epsilon}{R+r} \right) = \frac{V}{L} \times l_2 \Rightarrow \frac{R\epsilon}{R+r} = \frac{V}{L} \times 100 \quad \dots(ii)$$

Dividing eqn. (i) and (ii),  $\frac{(R+r)}{R} = \frac{110}{100}$

$$\Rightarrow 1 + \frac{r}{R} = \frac{110}{100} \Rightarrow \frac{r}{R} = \frac{110}{100} - \frac{100}{100}$$

$$\Rightarrow r = R \cdot \frac{10}{100} = \frac{R}{10} \quad \text{As } R = 10 \Omega ; r = 1 \Omega.$$

39. (c) : Power =  $220 \text{ V} \times 4 \text{ A} = 880 \text{ watts} = 880 \text{ J/s}$ .  
Heat needed to raise the temperature of  $1 \text{ kg}$  water through  $80^\circ\text{C}$

$$= ms \Delta T \times 4.2 \text{ J/cal}$$

$$= 1000 \text{ g} \times 1 \text{ cal/g} \times 80 \times 4.2 \text{ J/cal}$$

$$\therefore \text{time taken} = \frac{1000 \times 1 \times 80 \times 4.2}{880} = \frac{336 \times 10^3}{880}$$

$$= 382 \text{ s} = 6.3 \text{ min}$$

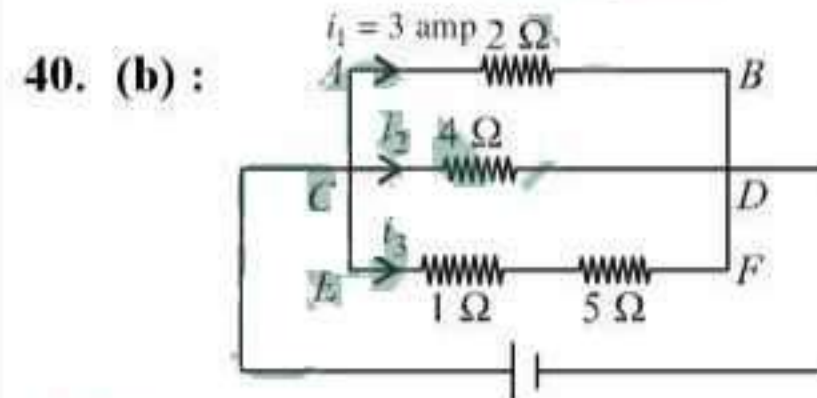

$2 \Omega, 4 \Omega$  and  $(1 \Omega + 5 \Omega)$  are in parallel.

So potential difference is the same.

$$V = 2 \Omega \cdot i_1 = 4 \Omega \cdot i_2 = 6 \Omega \cdot i_3$$

$$2 \cdot 3 = 6 \Omega \cdot i_3 \Rightarrow i_3 = 1 \text{ amp}$$

Total P.D. =  $5 \times 1 + 1 \times 1 = 6 \text{ V}$ .

∴ Power dissipated in  $5 \Omega$  resistance =  $\frac{V'^2}{R}$

where  $V'$  is the P.D. across  $5 \Omega = 5 \text{ V}$ .

∴ Power =  $\frac{25}{5 \Omega} = 5 \text{ watt}$

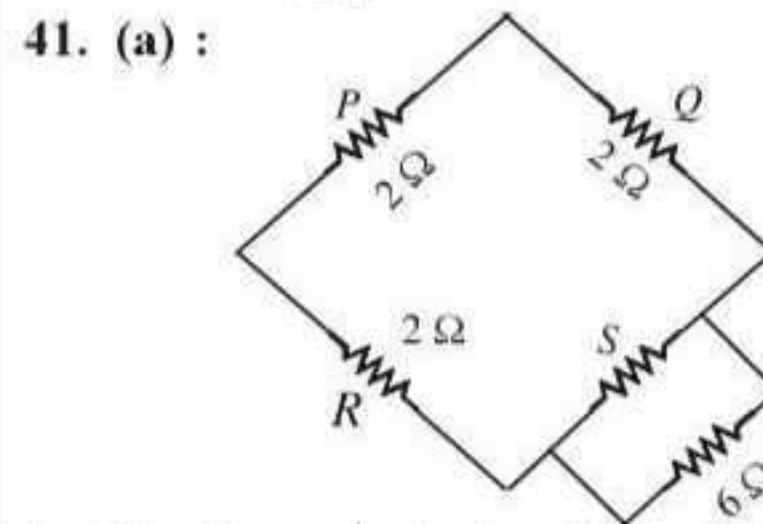

Let  $X$  be the equivalent resistance between  $S$  and  $6 \Omega$ .

$$\therefore \frac{1}{X} = \frac{1}{S} + \frac{1}{6} \quad \dots (i)$$

Therefore, the equivalent circuit diagram drawn below.

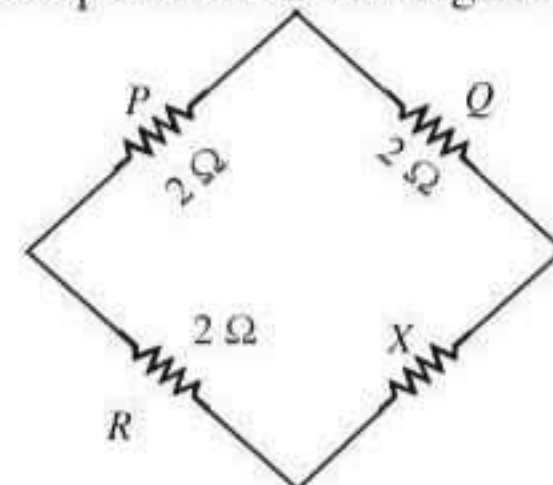

For a balanced Wheatstone bridge, we get

$$\frac{P}{Q} = \frac{R}{X} \quad \text{or} \quad \frac{2}{2} = \frac{2}{X} \Rightarrow X = 2 \Omega.$$

From eqn. (i), we get

$$\frac{1}{2} = \frac{1}{S} + \frac{1}{6} \quad \text{or,} \quad \frac{1}{S} = \frac{2}{6} \quad \text{or,} \quad S = 3 \Omega.$$

**42. (b) :** In the given circuit  $6 \Omega$  and  $3 \Omega$  are in parallel, and hence its equivalent resistance is given by

$$\frac{1}{R_p} = \frac{1}{6} + \frac{1}{3} \quad \text{or} \quad R_p = 2 \Omega.$$

The equivalent circuit diagram is given in figure.

Total current in the circuit,

$$I = \frac{18}{2+4} = 3 \text{ A.}$$

Power in the circuit =  $VI = 18 \times 3 = 54$  watt.

**43. (a) :**

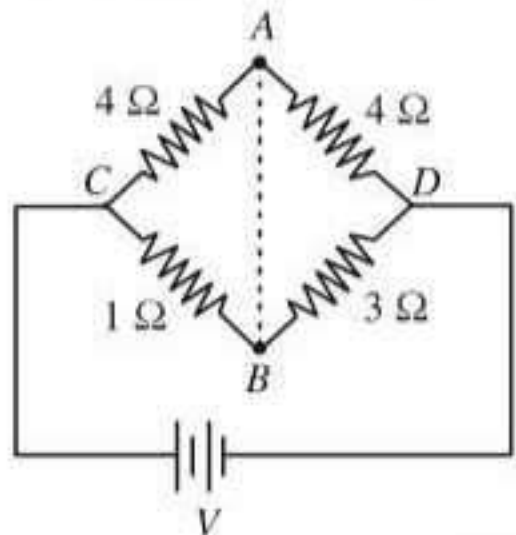

Current through arm  $CAD$ ,  $I = \frac{V}{8}$  amp

Potential difference between  $C$  and  $A = V_C - V_A$

$$= \frac{V}{8} \times 4 = \frac{V}{2} \text{ volt}$$

Current through  $CBD$ ,  $I' = \frac{V}{4}$  amp

Potential difference between  $C$  and  $B = V_C - V_B$

$$= \frac{V}{4} \times 1 = \frac{V}{4} \text{ volt.}$$

Potential between  $A$  and  $B = V_A - V_B$

$$\therefore V_A - V_B = V_C - V_B - (V_C - V_A) = \frac{V}{4} - \frac{V}{2} = -\frac{V}{4}$$

$\Rightarrow V_A - V_B < 0$  or,  $V_A < V_B$

As  $V_A < V_B$ , so direction of current will be from  $B$  to  $A$ .

**44. (c) :** Kirchhoff's first law of electrical circuit is based on conservation of charge and Kirchhoff's second law of electrical circuit is based on conservation of energy.

**45. (b) :** Kirchhoff's law has to be applied to the whole loop.

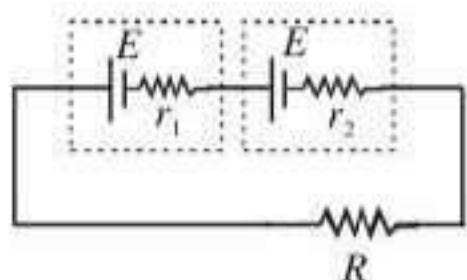

while  $i = \frac{2E}{(r_1 + r_2 + R)}$ ,

If through one section (here the first battery) has zero potential difference, current cannot flow. The question could have been modified.

The statement that when the circuit is closed, the potential difference across the first cell is zero implies that in a series circuit, one part cannot conduct current which is wrong. Kirchhoff's law is violated.

Assuming that  $ir_1 = E$  as given in the question paper, some students could have found that  $R = r_1 - r_2$ . They have to be given marks.

**46. (a) :** Resistance of series combination of  $3 \Omega$  and  $1 \Omega$  is

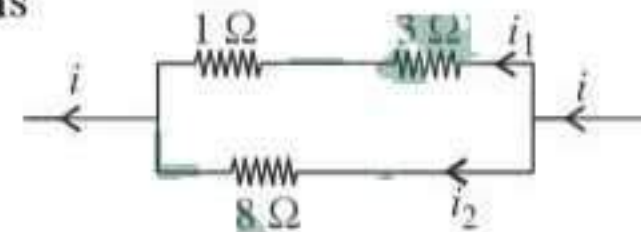

$$R_1 = 3 + 1 = 4 \Omega, R_2 = 8 \Omega$$

Let  $i$  be the total current in the circuit.

Current through  $R_1$  is  $i_1 = \frac{i \times R_2}{R_1 + R_2} = \frac{i \times 8}{12} = \frac{2i}{3}$

Current through  $R_2$  is  $i_2 = \frac{i \times R_1}{R_1 + R_2} = \frac{i \times 4}{12} = \frac{i}{3}$

Power dissipated in  $3 \Omega$  resistor is

$$P_1 = i_1^2 \times 3 \quad \dots (i)$$

Power dissipated in  $8 \Omega$  resistor is

$$P_2 = i_2^2 \times 8 \quad \dots (ii)$$

$$\therefore \frac{P_1}{P_2} = \frac{i_1^2 \times 3}{i_2^2 \times 8} \quad \text{or,} \quad \frac{P_1}{P_2} = \frac{(2i/3)^2 \times 3}{(i/3)^2 \times 8} = \frac{12}{8} = \frac{3}{2}$$

$$P_1 = \frac{3}{2} \times P_2 = \frac{3}{2} \times 2 = 3 \text{ watt}$$

$\therefore$  Power dissipated across  $3 \Omega$  resistor is 3 watt.

**47. (d) :** From Kirchhoff's law,

$$I \times 2 + I \times 1 = 18 - 12$$

Current in the circuit,

$$I = \frac{V}{R} = \frac{6}{3} = 2 \text{ A}$$

Voltage drop across  $2 \Omega$ ,

$$V_1 = 2 \times 2 = 4 \text{ V}$$

Voltmeter reading =  $18 - 4 = 14 \text{ V}$ .

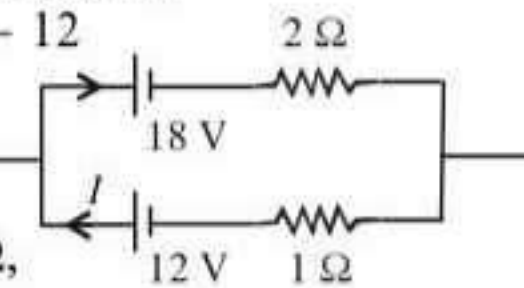

**48. (a) :** Both are in parallel.

$$\frac{1}{R'} = \frac{2}{R} + \frac{2}{R} = \frac{4}{R} \Rightarrow R' = \frac{R}{4}$$

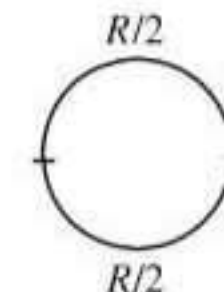

**49. (d) :** Since given circuit is in the form of Wheatstone bridge,

$$\frac{1}{R_{eq}} = \frac{1}{(4+2)} + \frac{1}{(6+3)}; \quad R_{eq} = 18/5 \Omega$$

$$V = iR_{eq} \Rightarrow i = \frac{V}{R_{eq}} = \frac{5V}{18}$$

50. (a) :  $P = i^2R$  or  $1 = 25 \times R$

$$R = \frac{1}{25} = 0.04 \Omega$$

51. (b) : Resistance of wire =  $\rho \frac{l}{A}$

$$R \propto \frac{l}{A} = \frac{l}{\pi r^2}$$

When length and radius are both doubled

$$R_1 \propto \frac{2l}{\pi(2r)^2} \Rightarrow R_1 \propto \frac{1}{2}R$$

The specific resistance of wire is independent of geometry of the wire, it only depends on the material of the wire.

52. (a) : When  $n$  resistance of  $r$  ohm connected in parallel then their equivalent resistance is

$$\Rightarrow \frac{1}{R} = \frac{1}{r} + \frac{1}{r} + \frac{1}{r} + \dots \dots \dots n \text{ times}$$

$$\therefore \frac{1}{R} = \frac{n}{r} \Rightarrow R = \frac{r}{n} \Rightarrow r = nR$$

When these resistance connected in series

$$R_s = r + r + \dots \dots \dots n \text{ times} \\ = nr = n \times nR = n^2R$$

53. (c) : Equivalent circuit of given circuit is shown in figure (i). Also this is equivalent to a balanced Wheatstone's bridge  $C$

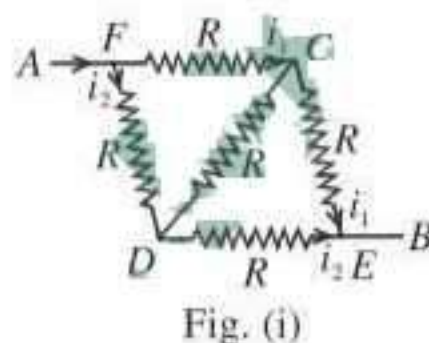

and  $D$  are at equal potential level, no current will flow in this resistance therefore this resistance can be neglected.

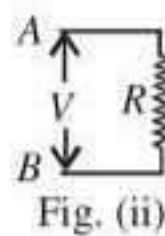

Thus equivalent resistance of this remaining circuit [in fig. (ii)] is  $R$ .

Then current in  $AFCEB$  branch is

$$i_1 = \frac{V}{R} \times \frac{2R}{2R + 2R} = \frac{V}{2R}$$

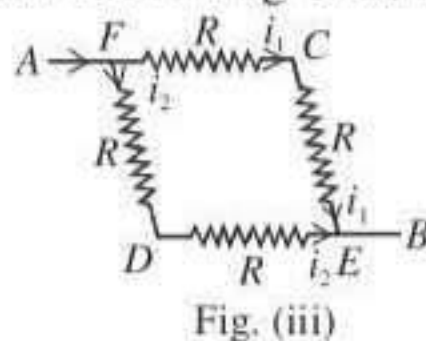

54. (c) : According to given parameters in question

$$\Rightarrow R = \rho \frac{l}{A} \Rightarrow 100 \Omega = \rho \frac{3}{A} \Rightarrow \frac{\rho}{A} = \frac{100}{3}$$

Thus total resistance of 50 cm wire is

$$R_1 = \frac{\rho}{A} l = \frac{100}{3} \times 0.5 = \frac{50}{3} \Omega$$

The total current in the wire is  $I = \frac{6}{100}$  A.

Therefore potential difference across the two points on the wire separated by a distance of 50 m is

$$(V) = IR_1 = \frac{50}{3} \times \frac{6}{100} = 1 \text{ V.}$$

55. (d) : The resistance of each bulb is

$$= \frac{V^2}{P} = \frac{(200)^2}{60} \Omega$$

When three bulbs are connected in series their resultant resistance =  $\frac{3 \times (200)^2}{60}$ .

Thus power drawn by bulb when connected across 200 V supply

$$P = \frac{V^2}{R_{re}} = \frac{(200)^2}{3 \times (200)^2 / 60} = 20 \text{ W.}$$

56. (c) : In India,  $P_I = \frac{(220)^2}{R}$

In USA,  $P_U = \frac{(110)^2}{R_U}$

$$\text{as } P_I = P_U \Rightarrow \frac{(220)^2}{R} = \frac{(110)^2}{R_U}$$

$$\Rightarrow R_U = \frac{110 \times 110}{220 \times 220} R = \frac{R}{4}$$

57. (c) : In balance Wheatstone bridge, the galvanometer arm can be neglected so equivalent resistance =  $R$ .

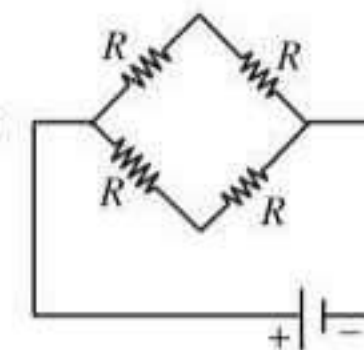

58. (d) :  $R = \frac{V^2}{P} = \frac{220 \times 220}{100} = 484 \Omega$

In series,  $R_{eq} = 484 + 484 = 968 \Omega$

$$\therefore P_{eq} = \frac{V^2}{968} = \frac{220 \times 220}{968} = 50 \text{ watt}$$

In parallel,  $R_{eq} = 242 \Omega$

$$\therefore P_{eq} = \frac{V^2}{242} = \frac{220 \times 220}{242} = 200 \text{ watt.}$$

59. (a) : Let  $R_1$  and  $R_2$  be the resistance of the two coils and  $V$  be the voltage supplied.

Effective resistance of two coils in parallel =  $\frac{R_1 R_2}{R_1 + R_2}$

Let  $H$  be the heat required to begin boiling in kettle.

$$\text{Then } H = \text{Power} \times \text{time} = \frac{V^2 t_1}{R_1} = \frac{V^2 t_2}{R_2}$$

$$\text{For parallel combination, } H = \frac{V^2 (R_1 + R_2) t_p}{R_1 R_2}$$

$$\Rightarrow \frac{1}{t_p} = \left( \frac{t_2 + t_1}{t_2 t_1} \right)$$

$$\therefore t_p = \frac{t_1 t_2}{t_1 + t_2} = \frac{10 \times 40}{10 + 40} = 8 \text{ minute.}$$

60. (b) : Fuse wire should have high resistance and low melting point.

61. (a) : Terminal potential difference is 2.2 V when circuit is open.

$\therefore$  e.m.f. of the cell  
 $= E = 2.2$  volt

Now, when the cell is connected to the external resistance, circuit current  $I$  is given by

$$I = \frac{E}{R+r} = \frac{2.2}{5+r} \text{ ampere, where } r \text{ is the internal resistance of the cell.}$$

Potential difference across the cell =  $IR$

$$= \frac{2.2}{5+r} \times 5 = 1.8.$$

$\therefore 5+r = 11/1.8.$

$$\therefore r = \frac{11}{1.8} - 5 = \frac{110-90}{18} = \frac{10}{9} \Omega.$$

62. (a) : Resistance of a conductor is given by

$R = \rho \frac{l}{A}$ , where  $\rho$  is the specific resistance,  $l$  is the length and  $A$  is the cross-sectional area of the conductor. Now, when  $l = 1$  and  $A = 1$ ,  $R = \rho$ .

So specific resistance or resistivity of a material may be defined as the resistance of a specimen of the material having unit length and unit cross-section. Hence, specific resistance is a property of a material and it will increase with the increase of temperature, but will not vary with the dimensions (length, cross-section) of the conductor.

63. (a) : For metals specific resistance decrease with decrease in temperature whereas for semiconductors specific resistance increases with decrease in temperature.

64. (a)

$$65. (a) : \frac{V}{l} = \frac{IR}{l} = \frac{I\rho l}{Al} = \frac{0.1 \times 10^{-7}}{10^{-6}} \\ = 0.01 = 10^{-2} \text{ V/m.}$$

66. (b) : This is a balanced Wheatstone's bridge so no current flows through the  $7 \Omega$  resistor.

$$\therefore \frac{1}{R_{eq}} = \frac{1}{4+3} + \frac{1}{6+8} \text{ or } R_{eq} = \frac{14}{3} \Omega$$

$$67. (c) : \frac{V-E}{r} = I \Rightarrow \frac{V-12}{5 \times 10^{-2}} = 60 \Rightarrow V = 15 \text{ V}$$

$$68. (b) : P = \frac{V^2}{R} \text{ or, } R \propto \frac{1}{P}$$

$$\therefore R_{40} > R_{100}$$

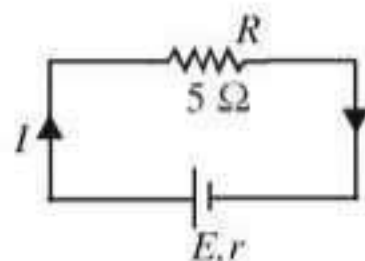

69. (a)

70. (d) : In given circuit  $R_B$  and  $R_C$  are in series.

$$\therefore R_{BC} = 6 + 6 = 12 \Omega.$$

Now,  $R_A$  and  $R_{BC}$  are in parallel.

Therefore, equivalent resistance of circuit,

$$R_{eq} = \frac{12 \times 3}{12+3} = \frac{36}{15}.$$

$$\text{Using Ohm's law, } I = \frac{V}{R_{eq}} = \frac{4.8}{36/15} = 2 \text{ A.}$$

$$71. (a) : i = \frac{2}{4} = 0.5 \text{ Ampere}$$

$$V = \varepsilon - ir$$

$$\text{or } V = 2 - 0.5 \times 0.1 = 1.95 \text{ V}$$

72. (d) : Metre bridge works on the principle of Wheatstone bridge.

$$\therefore \frac{P}{Q} = \frac{l}{100-l}$$

$$\text{or, } P = \frac{l}{100-l} \times Q = \frac{20}{80} \times 1 = 0.25 \Omega.$$

$$73. (c) : i = \frac{2}{10} = 0.2 \text{ A, } \frac{R}{l} = 10/4$$

Potential difference per unit length

$$= 0.2 \times (10/4) = 0.5 \text{ V/m}$$

74. (a)

75. (d) : For series,  $R_{eq} = 3r$

$$\text{Power} = \frac{V^2}{3r} = 10 \Rightarrow \frac{V^2}{r} = 30.$$

For parallel  $R_{eq} = r/3$

$$\text{power} = \frac{V^2}{r/3} = \frac{3V^2}{r} = 3 \times 30 = 90 \text{ watt.}$$

76. (a) :  $H = I^2 R t = ms \Delta T$

$$\frac{I_1^2}{I_2^2} = \frac{\Delta T_1}{\Delta T_2} \text{ or, } \Delta T_2 = \frac{\Delta T_1 I_2^2}{I_1^2}$$

$$\Delta T_2 = 5 \times \frac{(2I_1)^2}{I_1^2} = 20; \quad \Delta T_2 = 20^\circ \text{C.}$$

77. (a) : Three wires of lengths and cross-sectional areas =  $(l, A)$ ,  $(2l, A/2)$  and  $(l/2, 2A)$ .

Resistance of a wire  $(R) \propto \frac{l}{A}$ .

For I<sup>st</sup> wire,  $R_1 \propto l/A = R$

For II<sup>nd</sup> wire,  $R_2 \propto \frac{2l}{A/2} = 4R$

For III<sup>rd</sup> wire,  $R_3 \propto \frac{l/2}{2A} = \frac{R}{4}$

Therefore resistance of the wire will be minimum for III<sup>rd</sup> wire.

78. (b) : Applied voltage ( $V$ ) = 2V and resistances =  $3\Omega, 3\Omega, 3\Omega$ .

From the given circuit, we find that two resistances are in series and third resistance is in parallel. Therefore equivalent resistance for series resistances =  $3 + 3 = 6\Omega$ . Now it is connected parallel with  $3\Omega$  resistance. Therefore

$$\frac{1}{R} = \frac{1}{3} + \frac{1}{6} = \frac{3}{6} = \frac{1}{2} \quad \text{or } R = 2\Omega.$$

And current flowing in the circuit ( $I$ )

$$= \frac{V}{R} = \frac{2}{2} = 1\text{A}.$$

79. (c)

80. (a) : For the negative resistance, when we increase the voltage, the current will decrease. Therefore from the graph, we find that the current in  $CD$  is decreased when voltage is increased.

81. (c) : Power = 100 W, Voltage of bulb = 200 V and supply voltage ( $V_s$ ) = 160 V.

Therefore resistance of bulb ( $R$ )

$$= \frac{V^2}{P} = \frac{(200)^2}{100} = 400\Omega$$

and power consumption ( $P$ )

$$= \frac{V_s^2}{R} = \frac{(160)^2}{400} = 64\text{ W}.$$

82. (c) : 1 kWh = 1000 Wh

$$= (1000\text{ W}) \times (3600\text{ s}) = 36 \times 10^5\text{ J}$$

83. (d) : Ratio of resistance  $R_1 : R_2 = 1 : 2$  or  $\frac{R_1}{R_2} = \frac{1}{2}$ .

In series combination, power dissipated ( $P$ ) =  $I^2R$

$$\Rightarrow P \propto R. \text{ Therefore } \frac{P_1}{P_2} = \frac{R_1}{R_2} = \frac{1}{2}$$

or  $P_1 : P_2 = 1 : 2$ .

84. (a) : Lower resistance on extreme left and upper resistance on extreme right are ineffective.

The resistance  $R_2$  and  $R_3$  are in series combination. Therefore their equivalent resistance,

$$R' = R_2 + R_3 = 10 + 10 = 20\Omega.$$

Similarly, the resistance  $R_5$  and  $R_6$  are in series combination. Therefore their equivalent resistance,

$$R'' = R_5 + R_6 = 10 + 10 = 20\Omega.$$

Now the equivalent resistances  $R'$  and  $R''$  are in parallel combination. Therefore their equivalent resistance,

$$R''' = \frac{R'R''}{R'+R''} = \frac{20 \times 20}{20+20} = \frac{400}{40} = 10\Omega.$$

Thus equivalent resistance between  $A$  and  $D$ ,  $R$

$$= R_1 + R''' + R_4 = 10 + 10 + 10 = 30\Omega$$

( $\because$  series combination)

85. (d) : The circuit is equivalent to a balanced Wheatstone bridge. Therefore resistance between  $A$  and  $B$  is  $2\Omega$ .

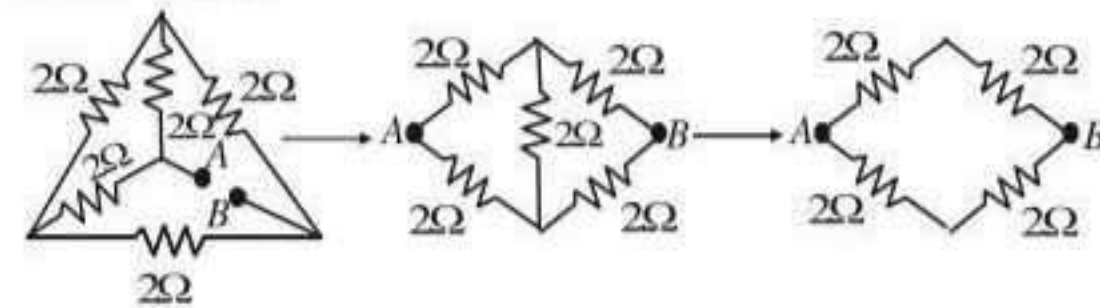

86. (a) : Ratio of cross-sectional areas of the wires =  $3 : 1$  and resistance of thick wire ( $R_1$ ) =  $10\Omega$ .

$$\text{Resistance } (R) = \rho \frac{l}{A} \propto \frac{1}{A}$$

$$\text{Therefore } \frac{R_1}{R_2} = \frac{A_2}{A_1} = \frac{1}{3} \quad \text{or } R_2 = 3R_1 = 3 \times 10 = 30\Omega$$

and equivalent resistance of these two resistances in series combination

$$= R_1 + R_2 = 10 + 30 = 40\Omega.$$

87. (a)

88. (b) : Power of heating coil = 100 W and voltage ( $V$ ) = 220 volts. When the heating coil is cut into two equal parts and these parts are joined in parallel, the resistance of the coil is reduced to one-fourth of the previous value. Therefore energy liberated per second becomes 4 times. *i.e.*  $4 \times 100 = 400\text{ W}$ .

89. (d) : Capacitance ( $C$ ) =  $4\mu\text{F} = 4 \times 10^{-6}\text{ F}$ ; Voltage ( $V$ ) = 400 volts and resistance ( $R$ ) =  $2\text{ k}\Omega = 2 \times 10^3\Omega$ .

$$\text{Heat produced} = \text{Electrical energy stored} = \frac{1}{2} CV^2$$

$$= \frac{1}{2} \times (4 \times 10^{-6}) \times (400)^2 = 0.32\text{ J}.$$

90. (b) : Length ( $l$ ) = 50 cm = 0.5 m;

$$\text{Area } (A) = 1\text{ mm}^2 = 1 \times 10^{-6}\text{ m}^2;$$

Current ( $I$ ) = 4A and voltage ( $V$ ) = 2 volts.

$$\text{Resistance } (R) = \frac{V}{I} = \frac{2}{4} = 0.5\Omega \text{ and}$$

$$\text{Resistivity } (\rho) = R \times \frac{A}{l} = 0.5 \times \frac{1 \times 10^{-6}}{0.5} = 1 \times 10^{-6}\Omega\text{m}$$

91. (a) : Resistances  $R_{AF}$  and  $R_{FE}$  are in series combination. Therefore their equivalent resistance  $R' = R_{AF} + R_{FE} = 3 + 3 = 6\Omega$ . Now the resistance  $R_{AE}$  and equivalent resistance  $R'$  are in parallel combination. Therefore relation for their equivalent resistance

$$\frac{1}{R''} = \frac{1}{R'} + \frac{1}{R_{AE}} = \frac{1}{6} + \frac{1}{6} = \frac{2}{6} = \frac{1}{3} \Rightarrow R'' = 3\Omega.$$

We can calculate in the same manner for  $R_{ED}$ ,  $R_{AC}$ ,  $R_{DC}$  etc. and finally the circuit reduces as shown in the figure.

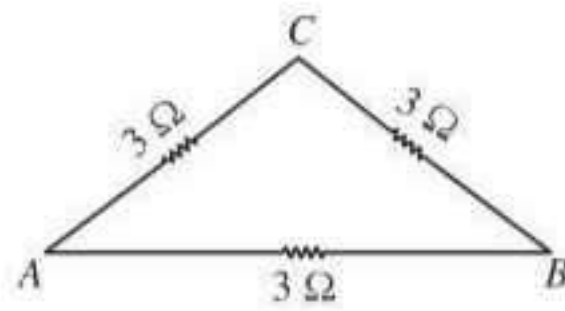

Therefore, the equivalent resistance between A and B

$$= \frac{(3+3) \times 3}{(3+3)+3} = 2 \Omega.$$

92. (a) : Flow of electrons,  $\frac{n}{t} = 10^7/\text{sec}.$

Therefore, current  $(I) = \frac{q}{t} = \frac{ne}{t} = \frac{n}{t} \times e$   
 $= 10^7 \times (1.6 \times 10^{-19}) = 1.6 \times 10^{-12} \text{ A}$

93. (c)

94. (d) : Power  $(P) = 60 \text{ W}$  and voltage  $(V) = 220 \text{ volts}.$

Resistance of the filament,  $R = \frac{V^2}{P} = \frac{(220)^2}{60} = 807 \Omega.$

95. (d) : The two resistances are connected in series and the resultant is connected in parallel with the third resistance.

$$\therefore R = 4 \Omega + 4 \Omega = 8 \Omega \text{ and } \frac{1}{R'} = \frac{1}{8} + \frac{1}{4} = \frac{3}{8}$$

or  $R' = \frac{8}{3} \Omega$

96. (c) : Current across  $3 \Omega = 0.8 \text{ A}$   
 $6 \Omega$  is in parallel, current across  $6 \Omega = 0.4 \text{ A}$   
 Total current =  $1.2 \text{ A}$

$\therefore$  potential difference across  $4 \Omega$  resistor =  $1.2 \text{ A} \times 4 \Omega = 4.8 \text{ V}.$

97. (a) : The output power of a cell is given by

$$P = \frac{V^2}{(r+R)^2} R$$

Maximum power is delivered to the load only when the internal resistance of the source is equal to the load resistance  $(R)$ . Then

$$P_{\text{max}} = \frac{V^2}{4R} = \frac{V^2}{4r} \quad (r = R)$$

98. (a)

99. (d) :

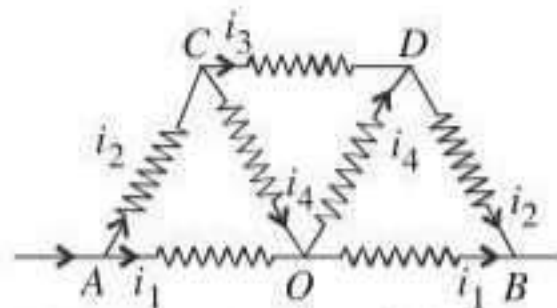

By symmetry, currents  $i_1$  and  $i_2$  from A is the same as  $i_1$  and  $i_2$  reaching B.

As the same current is flowing from A to O and O to B, O can be treated as detached from AB.

Now CO and OD will be in series hence its total resistance =  $2 \Omega$

It is in parallel with CD so equivalent resistance

$$= \frac{2 \times 1}{2+1} = \frac{2}{3} \Omega$$

This equivalent resistance is in series with AC and DB

So total resistance =  $\frac{2}{3} + 1 + 1 = \frac{8}{3} \Omega$

Now  $\frac{8}{3} \Omega$  is parallel to AB that is  $2 \Omega$  so total

resistance =  $\frac{(8/3) \times 2}{(8/3)+2} = \frac{16/3}{14/3} = \frac{16}{14} = \frac{8}{7} \Omega$

100. (b) : For maximum current, the two batteries should be connected in series. The current will be maximum when external resistance is equal to the total internal resistance of cells i.e.  $2 \Omega$ . Hence power developed across the resistance R will be

$$I^2 R = \left( \frac{2E}{R+2r} \right)^2 R = \left( \frac{2 \times 2}{2+2} \right)^2 \times 2 = 2 \text{ W}$$

101. (c) : To carry a current of 4 ampere, we need four path, each carrying a current of one ampere. Let r be the resistance of each path. These are connected in parallel. Hence their equivalent resistance will be  $r/4$ .

According to the given problem  $\frac{r}{4} = 5$  or  $r = 20 \Omega$ .

For this purpose two resistances should be connected. There are four such combinations. Hence, the total number of resistance =  $4 \times 2 = 8$

102. (b) :  $H = I^2 R t$  or  $R = \frac{H}{(I^2 t)} = \frac{80}{(2^2 \times 10)} = 2 \Omega$

103. (b) : Since, the voltage is same for the two combinations, the resistance is less for 39 bulbs. Hence the combination of 39 bulbs will glow more as current is more.

104. (c) : In series  $R_s = nR$

In parallel  $\frac{1}{R_p} = \frac{1}{R} + \frac{1}{R} + \dots n \text{ terms} = \frac{n}{R}$

$$\Rightarrow R_p = \frac{R}{n} \quad \therefore R_s/R_p = n^2/1$$

105. (a) :  $I = \frac{8-4}{1+2+9} = \frac{4}{12} = \frac{1}{3} \text{ A}$

$$V_p - V_q = 4 - \frac{1}{3} \times 3 = 3 \text{ Volt}$$

106. (d) :  $m = l \times \text{area} \times \text{density}$

$$\text{Area} \propto \frac{m}{l}$$

$$R \propto \frac{l}{\text{Area}} \propto \frac{l^2}{m}$$

$$R_1 : R_2 : R_3 = \frac{l_1^2}{m_1} : \frac{l_2^2}{m_2} : \frac{l_3^2}{m_3}$$

$$R_1 : R_2 : R_3 = \frac{25}{1} : \frac{9}{3} : \frac{1}{5} = 125 : 15 : 1$$

